

DEPTH GAGES

450, 450M DIAL DEPTH GAGES

0-12"/0-300MM

These depth gages are ideal for the individual mechanic. They are light, reliable and accurate for measurements to .001" or 0.02mm and will fit into most toolboxes.

450 Dial Depth Gages (.001" Graduation)			
Range	Description	Cat. No.	EDP
0-6"	6" Gage without Case	450-6	56766
0-12"	12" Gage without Case	450-12	56768
450M Dial Depth Gages (0.02mm Graduation)			
0-300mm	300mm Gage without Case	450M-300	64276
Accessories for 450 and 450M Dial Depth Gages			
Description	Cat. No.	EDP	
7"/175mm Base Extension	PT22287	65861	
12"/300mm Base Extension	PT22288	65862	
6" Case Only	450ZZ-6	56776	
12" Case Only	450ZZ-12	56777	

READABILITY FEATURES

- Sharp, easy-to-read dial graduations of .001-.100" or 0.02-2mm in one revolution
- Sharp, black graduations on the satin chrome finished bar, every .100" or 1mm

EASE-OF-HANDLING AND VERSATILITY FEATURES

- Lock screw for dial bezel
- Lock screw for holding the measuring rod in position
- Optional base extensions of 7" and 12" (175 and 300mm) are available to increase the base span on both models
- Removable hook attachment permits readings from the edge of a workpiece to edges of slots, shoulders, etc.

ACCURACY AND LONG-LIFE FEATURES

- Hardened, stainless steel base, measuring bar, rack and gears
- Positive split gear anti-backlash control

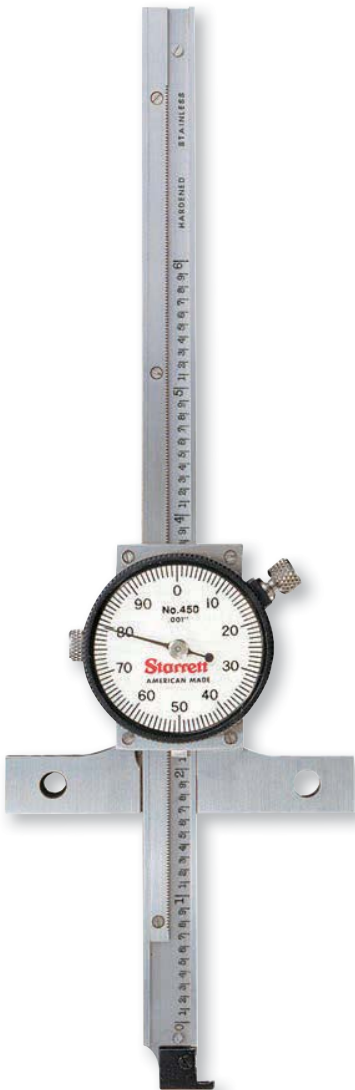

Left: 6" model
Below: 12"/300mm base extension



DEPTH GAGES

448, 448ME VERNIER DEPTH GAGES

0-12"/0-300MM

These are easy-to-use, very accurate depth gages. They are designed for measuring the depths of holes, slots, and recesses and for inspecting jig, fixtures and die work. They are also ideal for measuring from a plane surface to toolmakers' buttons for locating center distances. Readings are in .001" and 0.02mm.

- Heads are hardened, ground and lapped
- Measuring blades are hardened and ground and have accurate and sharp machine divided graduations
- All English graduations read to .001", with the bar being graduated in .025" increments
- All metric graduations read to 0.02mm, with the bar being graduated in 0.5mm increments
- Screw type adjusting nut allows for fine measuring adjustment
- Slide lock nut to hold measurement position
- Vernier plates are adjustable



448Z-6

Inch Reading/Graduation – .001"				
Range	Blades Furnished	Base Length x Width	Cat. No.	EDP
0-6"	One (6")	2-3/4 x 1/4"	448Z-6	52306
0-12"	One (12")		448Z-12	52308
0-12"	Two (6" and 12")		448Z-612	52310
Inch and Millimeter Reading/Graduation – .001" and 0.02mm – Both Edges				
0-6" (150mm)	One (6"/150mm)	2-3/4 x 1/4" (70 x 6.35mm)	448MEZ-6	52312
0-12" (300mm)	One (12"/300mm)		448MEZ-12	52314
0-12" (300mm)	Two (6"/150mm and 12"/300mm)		448MEZ-612	52316

237, 237M STEEL RULE DEPTH GAGES

0-6"/0-150MM

These very handy depth gages can be used to quickly obtain measurements in 64th of an inch or 1/2mm by simply adjusting the rule to the required depth.

- The gage consists of a nicely finished, hardened steel head and an accurate, machine divided, tempered steel rule. These rules are either our 610N (6") or our 635N (150mm) models.
- Gage can be smoothly adjusted to the required measurement and then locked into position by a knurled nut
- Base is cut out on one side, adjacent to the rule, permitting easier readings and more accurate measurements
- 6" hook rule (236HC, EDP 51077) also available, permitting easier readings from the edge of a workpiece to the edges of slots, shoulders, etc. Graduated in 32nds, 64ths.



237

237 Steel Rule Depth Gages (0-6" Range)			
Cat. No.	EDP	Graduation	Head Length x Width
237	51080	32nds, 64ths	2-5/8 x 1/8"
237M Steel Rule Depth Gages (0-150mm Range)			
237M	51081	mm, 1/2mm	66 x 3mm

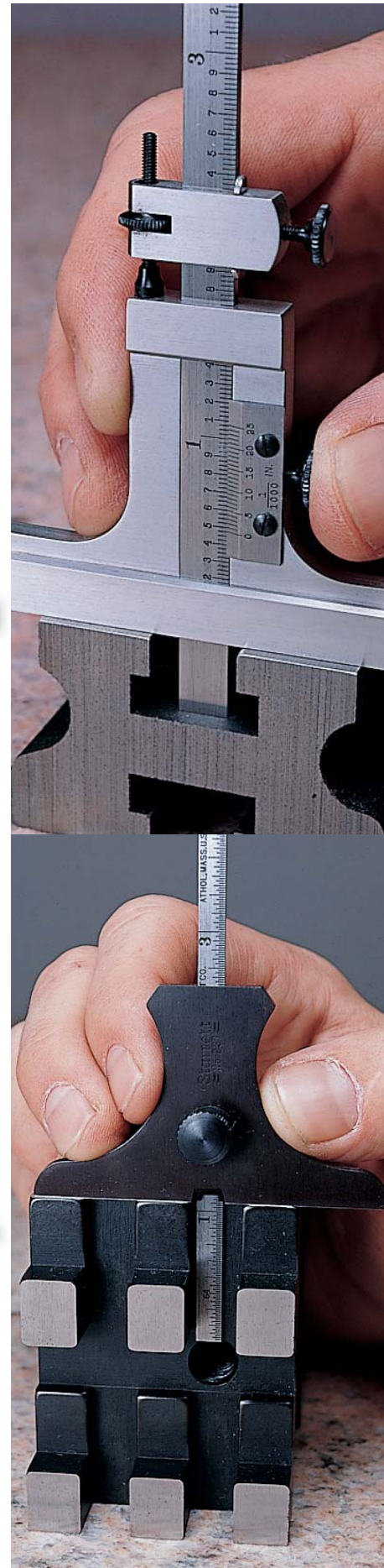

DEPTH GAGES

236, 236H COMBINATION STEEL RULE DEPTH AND ANGLE GAGES

0-6"

236

This depth gage has an added feature permitting its use as a protractor for measuring angles. It is a simple, handy tool that is a welcome addition to any machinist's toolbox.

- The head is graduated both left and right to 30, 45, and 60 degrees. The rule can be set to any of these angles by swinging the rule until the line on the turret coincides with the desired angle.
- Head is made of hardened steel, ground, and nicely polished – 2-5/8" (66mm) long and 1/8" (3mm) wide
- One side of the base is cut out to permit easier and more accurate readings
- The center of the head is recessed so that the tool will lay flat to permit more accurate measurements
- Tempered rule has been accurately machined divided, is smoothly fitted to the head, and can be locked in position by a knurled nut.

236H

These versatile gages can be used for calipering, as a depth gage by simply reversing the rule, as a protractor, and as a hook rule when removed from the tool.

Features are the same as the 236 except that a hook rule and an extra 6" (150mm) long rod are furnished with this gage. The rod has a 5/64" (2mm) diameter so it can measure the depth of small holes, slots, and recesses that the rule will not enter.

236 and 236H Combination Steel Rule Depth and Angle Gages (0-6" Range)				
Graduation	Angle Degrees	Description	Cat. No.	EDP
32nds, 64ths	30, 45, 60	6" Combination Gage	236	51074
		6" Combination Gage with Hook Rule	236HA	51075
		6" Combination Gage with Hook Rule and Rod	236HB	51076
32nds, 64ths	None	6" Hook Rule Only*	236HC	51077
None	None	6" Rod Only	236HD	51078

Also available on request with C610N-6 satin chrome rule.

* Hook rule only for 236, 236H, 237, 493 and 493B.

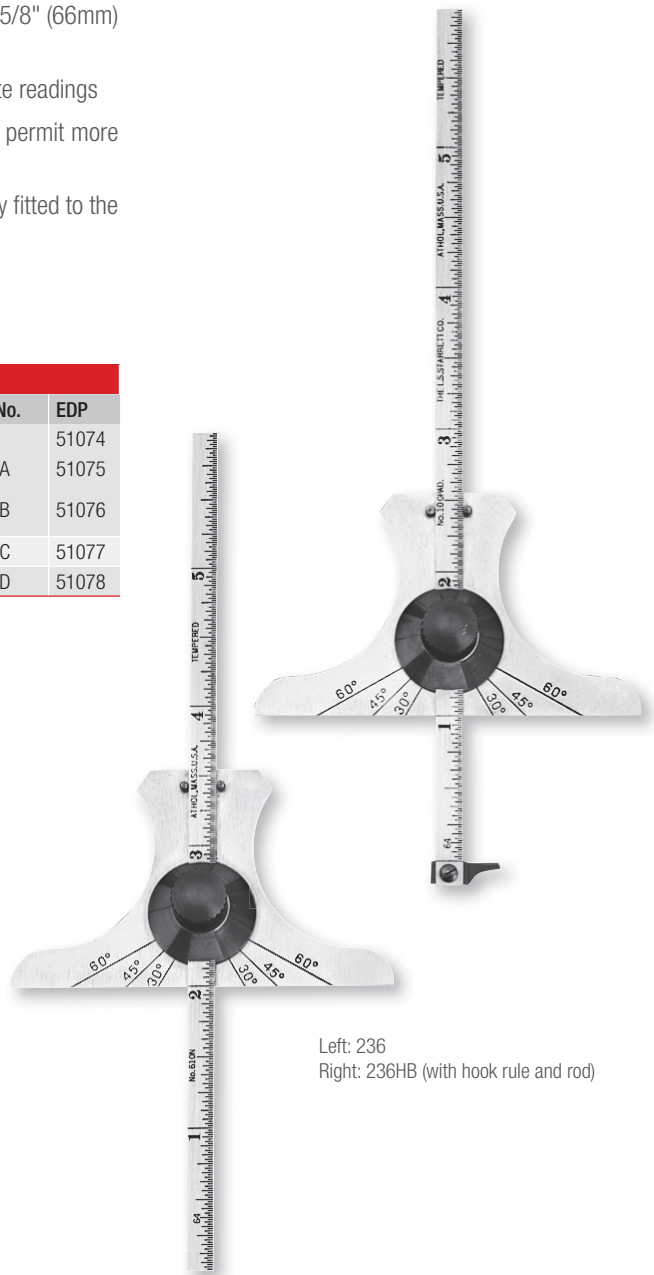

Left: 236
Right: 236HB (with hook rule and rod)



DEPTH GAGES

DIAL DEPTH GAGES

These depth gages are direct reading tools, referencing from their hardened and ground bases. All bases are 2-1/2" (64mm) long. They are quicker and more convenient to use than any other type of depth gage within their ranges and accuracy. Electronic Indicators can be furnished by special order.

640, 640M DIAL DEPTH GAGES

0-1/2"/0-10MM

640 DIAL DEPTH GAGES

The contact is slightly up into the base at rest. In action, the inspector sets the contact at zero, which is usually at the bottom of the base. Then the top button is pushed down to contact the work and the measurement is taken.



640R DIAL DEPTH GAGES

These gages are the same as the 640 except they have reverse movement (no push button) and can easily be used with one hand. Simply set on zero and apply the contact to the work and read the measurement.

640 Dial Depth Gages

Range	Graduation	Dial Reading	In Case	
			Cat. No.	EDP
0-1/2"	.0005"	0-50	640JZ	52705
			640RJZ	52709
0-10mm	0.01mm	0-100	640MJZ	55997
			640MRJZ	56001

643 DIAL DEPTH GAGE

0-.125"

This gage has a knife-edge base and a needle point contact which has been hardened and ground. The knife-edge base has a cutout so the conical point can be precisely positioned for close work. Point is 1/2" (12.7mm) long with a 40° included angle.



In action, the inspector gently pushes the point down to read zero with the base and then pushes down to make the needle point contact the workpiece to take the measurement.

643 Dial Depth Gages

Range	Graduation	Dial Reading	In Case		Without Case	
			Cat. No.	EDP	Cat. No.	EDP
0-.125"	.0005"	0-25-0	643JZ	52714	643J	52715

Electronic version available from Special Order Division.



DEPTH GAGES

644, 644M DIAL DEPTH GAGES

0-3"/0-75MM

These gages are for longer ranges, and are accurate and simple to use. Put the contact on the work to be measured and push the gage head down until the base stops at the reference point and take your reading.

Furnished with three rounded-end contact points to cover the range. Flat end contact points are also available on special order.

The zero setting can be checked with the shortest contact in place by pushing down on a flat surface.

644 Dial Depth Gages						
Range	Graduation	Dial Reading	In Case		Without Case	
			Cat. No.	EDP	Cat. No.	EDP
0-3"	.001"	0-100	644JZ	52718	644J	52719
0-75mm	0.01mm	0-100	644MJZ	56027	644MJ	56028



648 Depth Gage Bases will also accommodate the 644 Dial Depth Gage.

648 DEPTH GAGE BASES

Depth gage base with 25SC38 Stem Collet to fit 3/8" (9.5mm) stem dia. (as per AGD). Split bushings for adapting stem diameter are available but not included.

648 Depth Gage Bases		
Base Size	Cat. No.	EDP
4" (100mm)	648-4	65850
6" (150mm)	648-6	65851
8" (200mm)	648-8	65852

DEPTH GAGES



DEPTH GAUGES

642, 642M TOP READING DIAL DEPTH GAUGES

0-8.6"/0-215MM

This dial depth gage uses the back-plunger indicator to provide an upward-facing dial for easier readout. The operator selects the extension and contact point required, zeros the tool on a master and then reads any deviation of the work directly on the dial.

- Indicator does not have to be repositioned to get the full range available
- Choice of 2-1/2" (60mm) or 4" (100mm) base
- Two contacts and five extensions extend the range to 8.6" or 215mm
- Charts are supplied showing combinations of contacts and extensions required to achieve certain lengths



Above: 642AZ side view
Below: top view



642 Top Reading Dial Depth Gages					
Range	Graduation	Dial Indicator Range	Approx. Base Length	Cat. No.	EDP
0-8.6"	.001"	.200"	2-1/2"	642Z	65103
			4"	642AZ	65104
0-215mm	0.01mm	5mm	60mm	642MZ	65105
			100mm	642MAZ	65106

