

Precision Dial Gauges

The well thought-out design, accurate components and robust construction of our Precision Dial Gauge series offer reliability, durability and long working life. The standard features that enhance the quality across our entire product range are:

- Calibrations of all Dial Gauges are traceable to national and international standards.
- The final quality control for the whole series includes visual inspection and full mechanical functions' tests.
- Supplied with Declaration of Conformity and Confirmation of Traceability.
- Materials and components selected specifically to ensure a long working life.

Technical Benefits of our metric Precision Dial Gauges

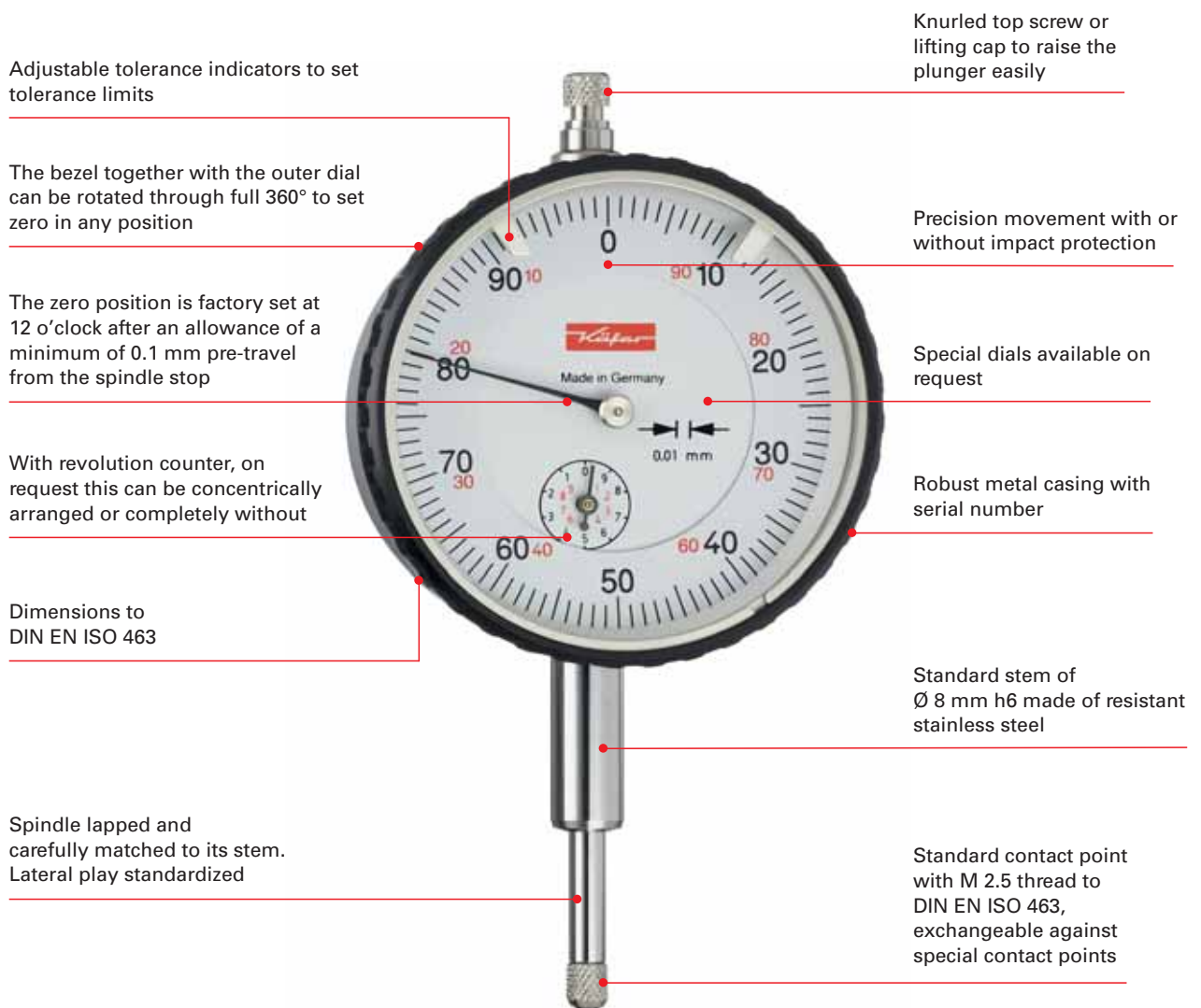

Precision Dial Gauges

Specifications of the Technical Data of Metric Dial Gauges

Page	Model	Reading	Range per revolution	Range	Bezel-Ø	Special Feature
42	KM 5 a	0.1 mm	5 mm	5 mm	40 mm	
42	KM 10 a	0.1 mm	10 mm	10 mm	40 mm	
–	KM 5 a R	0.1 mm	5 mm	5 mm	40 mm	Back Plunger
43	M 10 a	0.1 mm	10 mm	10 mm	58 mm	
43	M 10 b	0.1 mm	10 mm	20 mm	58 mm	
44	M 10 c	0.1 mm	10 mm	30 mm	58 mm	
44	M 10 d	0.1 mm	10 mm	50 mm	58 mm	
–	M 10/5 R	0.1 mm	5 mm	5 mm	58 mm	Back Plunger
–	SI-9/0.1	0.1 mm	–	8 mm	58 mm	Error Free
–	GM 10/80	0.1 mm	10 mm	20 mm	80 mm	
–	GM 10/100	0.1 mm	10 mm	10 mm	100 mm	
25	MU 28	0.01 mm	0.5 mm	3.5 mm	28 mm	
25	KM 6 T	0.01 mm	0.5 mm	3 mm	32 mm	
26	KM 4 T	0.01 mm	0.5 mm	3 mm	40 mm	
–	KM 4 T – 100	0.01 mm	1.0 mm	3 mm	40 mm	
28	KM 4 TOP	0.01 mm	0.5 mm	3 mm	40 mm	
–	KM 4 X	0.01 mm	0.5 mm	3 mm	40 mm	
30	KM 4 S	0.01 mm	0.5 mm	3 mm	40 mm	Shockproof
–	KM 4 S – 100	0.01 mm	1.0 mm	3 mm	40 mm	Shockproof
–	KM 4 TOP ,S'	0.01 mm	0.5 mm	3 mm	40 mm	Shockproof
–	KM 4 XS	0.01 mm	0.5 mm	3 mm	40 mm	Shockproof
27	KM 4/5 T	0.01 mm	0.5 mm	5 mm	40 mm	
29	KM 4/5 T – 100	0.01 mm	1.0 mm	5 mm	40 mm	
–	KM 4/5 TOP	0.01 mm	0.5 mm	5 mm	40 mm	
–	KM 4/5 X	0.01 mm	0.5 mm	5 mm	40 mm	
31	KM 4/5 S	0.01 mm	0.5 mm	5 mm	40 mm	Shockproof
–	KM 4/5 S – 100	0.01 mm	1.0 mm	5 mm	40 mm	Shockproof
28	KM 4/5 TOP ,S'	0.01 mm	0.5 mm	5 mm	40 mm	Shockproof
–	KM 4/5 XS	0.01 mm	0.5 mm	5 mm	40 mm	Shockproof
29	KM 4/10 TK – 100	0.01 mm	1.0 mm	10 mm	40 mm	Concentric Hands
45	KM 4 R	0.01 mm	0.5 mm	3 mm	40 mm	Back Plunger
45	KM 4/5 R	0.01 mm	0.5 mm	5 mm	40 mm	Back Plunger
48	SI-45	0.01 mm	–	0.4 mm	40 mm	Error Free
–	SI-45 W	0.01 mm	–	0.4 mm	44.5 mm	Error Free
48	SI-45/0.8	0.01 mm	–	0.8 mm	40 mm	Error Free
54	KM 4 SW	0.01 mm	0.5 mm	3 mm	44.5 mm	Waterproof
54	KM 4/5 SW	0.01 mm	0.5 mm	5 mm	44.5 mm	Waterproof
–	KM 4 S wa	0.01 mm	0.5 mm	3 mm	41 mm	Water Protected
102	KM 4 T Magnet	0.01 mm	0.5 mm	3 mm	40 mm	Magnetic Back
7	M 2 T	0.01 mm	1 mm	10 mm	58 mm	
8	M 2 TK	0.01 mm	1 mm	10 mm	58 mm	
9	M 2 T with special fittings	0.01 mm	1 mm	10 mm	58 mm	Concentric Hands
10	M 2 T with special fittings	0.01 mm	1 mm	10 mm	58 mm	Extended Stem, Special Dials
11	M 2 TOP	0.01 mm	1 mm	10 mm	58 mm	Reverse Spring Traction, Two Stems
12	M 2 X	0.01 mm	1 mm	10 mm	58 mm	
13	MU 52 T	0.01 mm	1 mm	10 mm	58 mm	
15	M 2 S	0.01 mm	1 mm	10 mm	58 mm	Fine adjustment of the hand
14	M 2 SN	0.01 mm	1 mm	10 mm	58 mm	Shockproof
16	M 2 TOP ,S'	0.01 mm	1 mm	10 mm	58 mm	Shockproof
16	M 2 XS	0.01 mm	1 mm	10 mm	58 mm	Shockproof
13	MU 52 ST	0.01 mm	1 mm	10 mm	58 mm	Shockproof
17	M 3 T	0.01 mm	0.5 mm	5 mm	58 mm	
17	M 3 S	0.01 mm	0.5 mm	5 mm	58 mm	Shockproof
18	M 2/20 T	0.01 mm	1 mm	20 mm	58 mm	
18	M 2/20 S	0.01 mm	1 mm	20 mm	58 mm	Shockproof
18	M 2/25 T	0.01 mm	1 mm	25 mm	58 mm	Compact Size
18	M 2/25 S	0.01 mm	1 mm	25 mm	58 mm	Compact Size, Shockproof
19	M 2/30 T	0.01 mm	1 mm	30 mm	58 mm	
20	M 2/30 S	0.01 mm	1 mm	30 mm	58 mm	Shockproof
21	MU 2/30 T	0.01 mm	1 mm	30 mm	58 mm	
21	MU 2/30 S	0.01 mm	1 mm	30 mm	58 mm	Shockproof
22	M 2/50 T	0.01 mm	1 mm	50 mm	58 mm	
22	M 2/50 S	0.01 mm	1 mm	50 mm	58 mm	Shockproof
21	M 2/80 T	0.01 mm	1 mm	80 mm	58 mm	
21	M 2/80 S	0.01 mm	1 mm	80 mm	58 mm	Shockproof
–	M 2/100 T	0.01 mm	1 mm	100 mm	58 mm	Stem dia. 10 mm

>>>

Precision Dial Gauges

Specifications of the Technical Data of Metric Dial Gauges

Page	Model	Reading	Range per revolution	Range	Bezel-Ø	Special Feature
46	M 2 R	0.01 mm	1 mm	3 mm	58 mm	Back Plunger
46	M 2/5 R	0.01 mm	1 mm	5 mm	58 mm	Back Plunger
56	M 2 R W	0.01 mm	1 mm	3 mm	58 mm	Back Plunger, Waterproof
49	SI-90	0.01 mm	–	0.8 mm	58 mm	Error Free
–	SI-90 X	0.01 mm	–	0.8 mm	58 mm	Error Free
51	MU 52 ST – SI	0.01 mm	–	0.8 mm	58 mm	Error Free
–	SI-90 R	0.01 mm	–	0.8 mm	58 mm	Error Free
57	SI-90 W	0.01 mm	–	0.8 mm	61.5 mm	Error Free
49	SI-18	0.01 mm	–	1.6 mm	58 mm	Error Free
55	M 2 SW	0.01 mm	1 mm	10 mm	61.5 mm	Waterproof
–	M 2/30 SW	0.01 mm	1 mm	30 mm	61.5 mm	Waterproof
60	M 2 S wa	0.01 mm	1 mm	10 mm	58 mm	Water Protected
102	M 2 T Magnet	0.01 mm	1 mm	10 mm	58 mm	Magnetic Back
32	GM 80 T	0.01 mm	1 mm	10 mm	80 mm	
32	GM 80 S	0.01 mm	1 mm	10 mm	80 mm	Shockproof
–	GM 80/30 T	0.01 mm	1 mm	30 mm	80 mm	
–	GM 80/50 T	0.01 mm	1 mm	50 mm	80 mm	
–	GM 80/100 T	0.01 mm	1 mm	100 mm	80 mm	Stem dia. 10 mm
58	GM 80 SW	0.01 mm	1 mm	10 mm	80 mm	Waterproof
32	GM 100 T	0.01 mm	1 mm	10 mm	100 mm	
32	GM 100 S	0.01 mm	1 mm	10 mm	100 mm	Shockproof
–	GM 100/30 T	0.01 mm	1 mm	30 mm	100 mm	
–	GM 100/50 T	0.01 mm	1 mm	50 mm	100 mm	
17	M 3 a T	0.005 mm	0.5 mm	5 mm	58 mm	
17	M 3 a S	0.005 mm	0.5 mm	5 mm	58 mm	Shockproof
–	M 3 a SI	0.005 mm	–	0.4 mm	58 mm	Error Free
–	KM 500 T	0.002 mm	0.2 mm	1 mm	40 mm	
34	KM 500 S	0.002 mm	0.2 mm	1 mm	40 mm	Shockproof
–	KM 500/3 S	0.002 mm	0.2 mm	3 mm	40 mm	Shockproof
–	KM 500 R	0.002 mm	0.2 mm	1 mm	40 mm	Back Plunger
–	KM 500 SI	0.002 mm	–	0.16 mm	40 mm	Error Free
–	KM 500 SW	0.002 mm	0.2 mm	1 mm	44.5 mm	Waterproof
36	FM 500 T	0.002 mm	0.2 mm	1 mm	58 mm	
–	FM 500 R	0.002 mm	0.2 mm	1 mm	58 mm	Back Plunger
–	FM 500 SI	0.002 mm	–	0.16 mm	58 mm	Error Free
–	KM 1000 T	0.001 mm	0.2 mm	1 mm	40 mm	
–	KM 1000 S	0.001 mm	0.2 mm	1 mm	40 mm	Shockproof
39	Feinika KM 1101	0.001 mm	0.1 mm	1 mm	40 mm	Shockproof, extra accurate
–	KM 1000 R	0.001 mm	0.2 mm	1 mm	40 mm	Back Plunger
52	Feinika SI-914	0.001 mm	–	0.08 mm	40 mm	Error Free
–	Feinika SI-910	0.001 mm	–	0.10 mm	40 mm	Error Free
–	KM 1000 SI	0.001 mm	–	0.16 mm	40 mm	Error Free
–	KM 1000 S wa	0.001 mm	0.2 mm	1 mm	40 mm	Water Protected
–	Feinika KM 1101 W	0.001 mm	0.1 mm	1 mm	44.5 mm	Waterproof
36	FM 1000 T	0.001 mm	0.2 mm	1 mm	58 mm	
–	FM 1000 S	0.001 mm	0.2 mm	1 mm	58 mm	Shockproof
40	Feinika FM 1101	0.001 mm	0.1 mm	1 mm	58 mm	Shockproof, extra accurate
37	FM 1000/5 T	0.001 mm	0.2 mm	5 mm	58 mm	
–	FM 1000/5 S	0.001 mm	0.2 mm	5 mm	58 mm	Shockproof
52	Feinika SI-915	0.001 mm	–	0.08 mm	58 mm	Error Free
–	Feinika SI-916	0.001 mm	–	0.10 mm	58 mm	Error Free
–	Feinika SI-918	0.001 mm	–	0.16 mm	58 mm	Error Free
–	SI-180	0.001 mm	–	0.16 mm	58 mm	Error Free
–	FM 1000 S wa	0.001 mm	0.2 mm	1 mm	58 mm	Water Protected
59	FM 1000 SW	0.001 mm	0.2 mm	1 mm	61.5 mm	Waterproof
–	FM 1101 W	0.001 mm	0.1 mm	1 mm	61.5 mm	Waterproof
–	FM 1000/5 S wa	0.001 mm	0.2 mm	5 mm	58 mm	Water Protected
59	FM 1000/5 SW	0.001 mm	0.2 mm	5 mm	61.5 mm	Waterproof
–	FM 1000/80 T	0.001 mm	0.2 mm	1 mm	80 mm	
–	FM 1000/80 S	0.001 mm	0.2 mm	1 mm	80 mm	Shockproof
–	FM 1000/80-5 T	0.001 mm	0.2 mm	5 mm	80 mm	
–	FM 1000/80-5 S	0.001 mm	0.2 mm	5 mm	80 mm	Shockproof

Dial Gauge M 2 T

A well thought-out design, the use of high-quality components and materials as well as the precision engineered mechanism guarantee the outstanding quality of the Precision Dial Gauge M 2 T.

All details of this Dial Gauge conform to DIN 878 in conjunction with DIN EN ISO 463. This applies not only to the outside dimensions but also to allowed tolerances, the measuring force and the measuring force reversal range.

Spindle and stem are made of resistant stainless steel. The spindle is lapped.

Precision Dial Gauge M 2 T	
Reading	0.01 mm
Range	10 mm
Range per revolution	1 mm
Bezel-Ø	58 mm
Stem-Ø	8 h 6
Dimensions and accuracy according to	DIN EN ISO 463/DIN 878
Initial measuring force	0.7 N
Dimensioned drawing	page 8



Optionally, the Dial Gauge M 2 T is also available with special fittings:

- **Dial Gauge M 2 T**
with fixing screw for the bezel
- **Dial Gauge M 2 T**
with lifting device
- **Dial Gauge M 2 T**
with special transmission ratio
(range per revolution = 2, 5 or 10 mm)
- **Dial Gauge M 2 T**
with counter clockwise dial reading
- **Dial Gauge M 2 T**
with balanced dial reading 0-50-0
- **Dial Gauge M 2 T**
with increased measuring force
- **Dial Gauge M 2 T**
with reduced measuring force
- **Dial Gauge M 2 T**
with reverse spring traction
- **Dial Gauge M 2 T**
with extended stem
- **Dial Gauge M 2 T**
with two stems: top and bottom

Model M 1 T is a Dial Gauge with the same technical data but with only one large hand and no revolution counter.

Dial Gauge M 2 TK

The technical features of Dial Gauge M 2 TK are the same as for model M 2 T.

Both pointers are concentrically arranged on the Dial Gauge M 2 TK. This allows particularly clear reading.

On request this Dial Gauge can also be supplied in a shockproof version.



Precision Dial Gauge M 2 TK	
Reading	0.01 mm
Range	10 mm
Range per revolution	1 mm
Bezel-Ø	58 mm
Stem-Ø	8 h 6
Dimensions and accuracy according to	DIN EN ISO 463/DIN 878
Initial measuring force	0.7 N
Dimensioned drawing	page 8

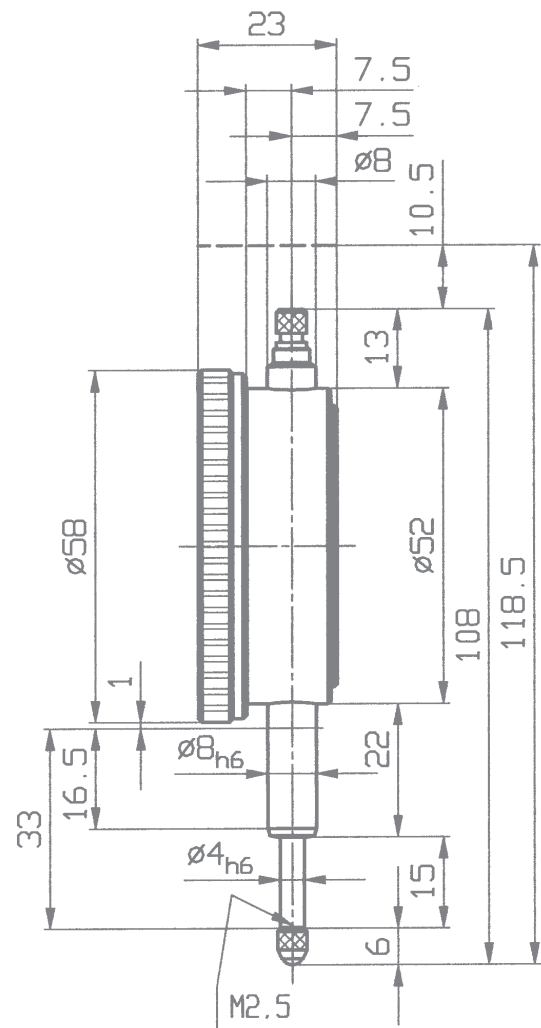

Dial Gauge M 2 T

with special fittings

Precision Dial Gauge M 2 T with extended stem

Reading	0.01 mm
Range	10 mm
Range per revolution	1 mm
Bezel-Ø	58 mm
Stem-Ø	8 h 6
Dimensions except for L ₂ and accuracy according to	DIN EN ISO 463/DIN 878
Hysteresis	fu = 5 µm
Stem lengths	50, 75, 100, 125 or 150 mm
Dimensioned drawing	on request

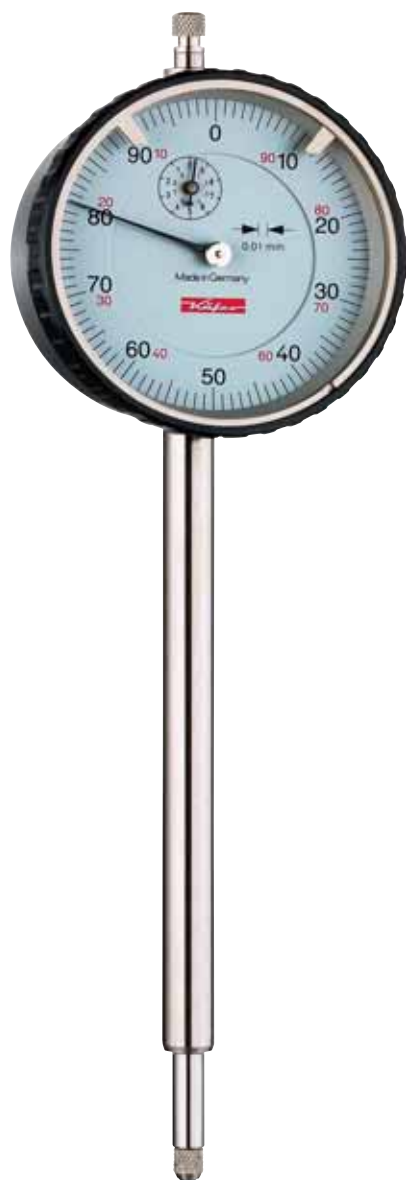

Precision Dial Gauge M 2 T with counter clockwise reading

Reading	0.01 mm
Range	10 mm
Range per revolution	1 mm
Bezel-Ø	58 mm
Stem-Ø	8 h 6
Dimensions and accuracy according to	DIN EN ISO 463 /DIN 878
Initial measuring force	0.7 N
Dimensioned drawing	page 8



On request other Dial Gauges from our manufacturing programme are available with extended stem, with counter clockwise reading or with balanced dial reading. Please request our offers.

Dial Gauge M 2 T

with special fittings

Precision Dial Gauge M 2 T with reverse spring traction	
Reading	0.01 mm
Range	10 mm
Range per revolution	1 mm
Bezel-Ø	58 mm
Stem-Ø	8 h 6
Dimensions and accuracy according to	DIN EN ISO 463/DIN 878
Hysteresis	$f_u = 5 \mu\text{m}$
Spindle	lapped
Dimensioned drawing	on request

Precision Dial Gauge M 2 T with two stems: top and bottom	
Reading	0.01 mm
Range	10 mm
Range per revolution	1 mm
Bezel-Ø	58 mm
Stem-Ø	8 h 6
Dimensions and accuracy according to	DIN EN ISO 463/DIN 878
Initial measuring force	0.7 N
Dimensioned drawing	on request



On request other Dial Gauges from our manufacturing programme are available with reverse spring traction or with two stems. Please request our offers.

Dial Gauge M 2 TOP

D.B.P. No. 36 43 200

We hold German patent no. 36 43 200 for TOP series Dial Gauges.

New technological production methods enable us to market it at an astonishingly low price.

All details of this Dial Gauge conform to DIN 878 in conjunction with DIN EN ISO 463. This applies not only to the dimensions but also to allowed tolerances.

Spindle and stem are made of resistant stainless steel. The spindle is lapped.

Precision Dial Gauge M 2 TOP	
Reading	0.01 mm
Range	10 mm
Range per revolution	1 mm
Bezel-Ø	58 mm
Stem-Ø	8 h 6
Dimensions and accuracy according to	DIN EN ISO 463/DIN 878
Initial measuring force	0.8 N
Dimensioned drawing	page 11

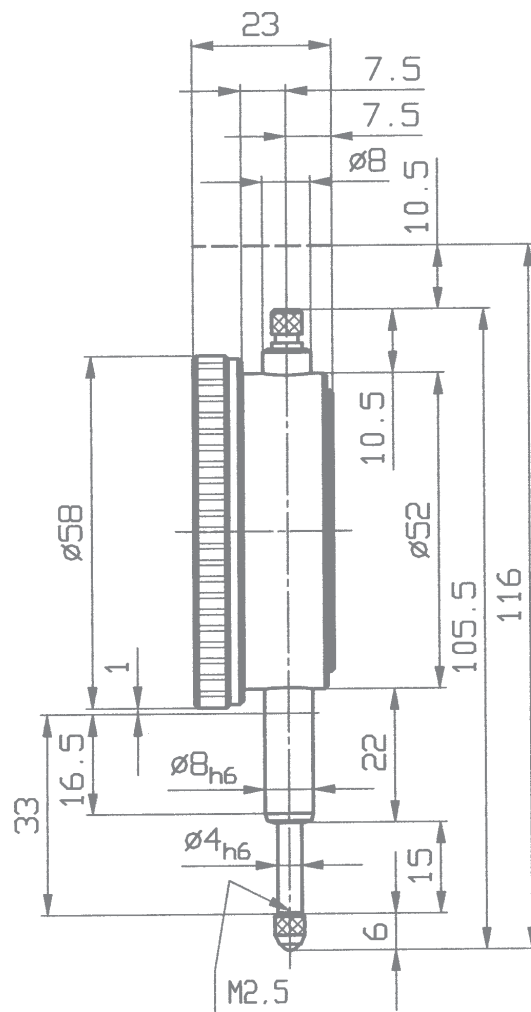

Dial Gauge M 2 X

Enabled by the use of a polyamide quality injection-moulded casing we can offer the Dial Gauge M 2 X having very low weight.

The successful design of the M 2 X Dial Gauge offers high precision at a low price.

All details of this Dial Gauge conform to DIN 878 in conjunction with DIN EN ISO 463. This applies not only to the dimensions but also to allowed tolerances.

Spindle and stem are made of stainless steel. The spindle is lapped.



Precision Dial Gauge M 2 X

Reading	0.01 mm
Range	10 mm
Range per revolution	1 mm
Bezel-Ø	58 mm
Stem-Ø	8 h 6
Dimensions and accuracy according to DIN EN ISO 463/DIN 878	
Initial measuring force	0.7 N
Dimensioned drawing	page 16

Thanks to an appropriate combination of quality injection-moulded parts and standard metal parts, we were able to create a new design of Dial Gauges.

The metal gear elements are inserted by simple means into two injection moulded parts. This substitutes for the conventional mechanism.

This nearly 20 year old design, in the past protected by German Federal Patent, has proved itself on the market.

Despite several improvements the basic concept has remained unchanged. Series 'X' Dial Gauges have become a trademark of our competence in the manufacture of Dial Gauges.

Dial Gauge MU 52 T

Dial Gauge MU 52 ST

shockproof



Our new Dial Gauge Series MU 52 has been designed and manufactured by Käfer Dial Gauges Shanghai. The racks and pinions – the key parts for the accuracy of Dial Gauges – are however supplied by Käfer Germany. All Dial Gauges are checked for their accuracy on a Feinmess Suhl automatic Dial Gauge Measuring Machine.

All details of these Dial Gauges conform to DIN EN ISO 463 / DIN 878. Except for the shockproof system all technical features of the Dial Gauge MU 52 ST are the same as for the MU 52 T Dial Gauge. Effective impact protection protects the Dial Gauge MU 52 ST even from hard impacts on the spindle, thereby reducing the risk of damage of the teeth.

Precision Dial Gauge MU 52 T

Reading	0.01 mm
Range	10 mm
Range per revolution	1 mm
Bezel-Ø	58 mm
Stem-Ø	8 h 6
Dimensions and accuracy according to DIN EN ISO 463/DIN 878	
Initial measuring force	0.7 N
Dimensioned drawing	page 13

Precision Dial Gauge MU 52 ST shockproof

Reading	0.01 mm
Range	10 mm
Range per revolution	1 mm
Bezel-Ø	58 mm
Stem-Ø	8 h 6
Dimensions and accuracy according to DIN EN ISO 463/DIN 878	
Initial measuring force	0.7 N
Dimensioned drawing	page 13

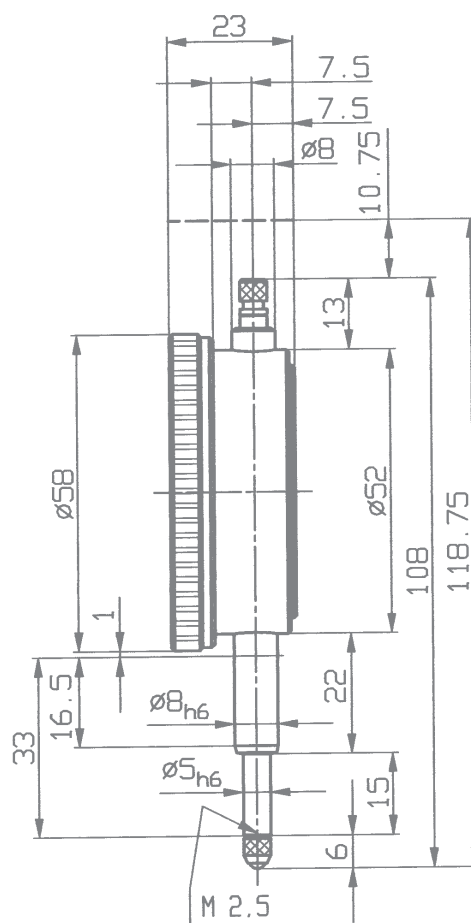

Dial Gauge M 2 SN

shockproof

With this shockproof series, a product of our extensive design expertise, we offer an accurate, reliable and long-lasting Dial Gauge.

A gear rack sleeve covering the length of the spindle is arranged and sprung in such a way that the shocks against the measuring insert are not transferred to the gauge movement. The Dial Gauge is robust in operation. Its precision is maintained with practically no limitations.

Spindle and stem are made of resistant stainless steel. The spindle is lapped.



Precision Dial Gauge M 2 SN shockproof

Reading	0.01 mm
Range	10 mm
Range per revolution	1 mm
Bezel-Ø	58 mm
Stem-Ø	8 h 6
Dimensions and accuracy according to DIN EN ISO 463/DIN 878	
Initial measuring force	0.8 N
Dimensioned drawing	same as SI-100 on page 50

Optionally, the Dial Gauge M 2 SN is also available with special fittings:

- **Dial Gauge M 2 SN**
with fixing screw for the bezel
- **Dial Gauge M 2 SN**
with threaded protective sleeve
- **Dial Gauge M 2 SN**
with concentric revolution counter instead of small revolution counter
- **Dial Gauge M 2 SN**
with special transmission ratio
(range per revolution = 2, 5 or 10 mm)
- **Dial Gauge M 2 SN**
with wire release for easy spindle lifting
- **Dial Gauge M 2 SN**
with counter clockwise dial reading
- **Dial Gauge M 2 SN**
with balanced dial reading 0-50-0
- **Dial Gauge M 2 SN**
with increased measuring force
- **Dial Gauge M 2 SN**
with reduced measuring force
- **Dial Gauge M 2 SN**
with reverse spring traction
- **Dial Gauge M 2 SN**
with extended stem

Dial Gauge M 2 TOP ,S'

shockproof, D.B.P. No. 36 43 200

Except for the additional shockproof system all technical features of the Dial Gauge M 2 TOP ,S' are the same as for the M 2 TOP Dial Gauge on page 11 of this catalogue. Effective impact protection protects the Dial Gauge M 2 TOP ,S' even from hard impacts on the spindle, thereby reducing the risk of damage to the teeth.

Spindle and stem are made of resistant stainless steel. The spindle is lapped.

Precision Dial Gauge M 2 TOP ,S' shockproof	
Reading	0.01 mm
Range	10 mm
Range per revolution	1 mm
Bezel-Ø	58 mm
Stem-Ø	8 h 6
Dimensions and accuracy according to DIN EN ISO 463/DIN 878	
Initial measuring force	0.8 N
Dimensioned drawing	page 11



Dial Gauge M 2 XS

shockproof

The Dial Gauge M 2 XS is another shockproof version. Its additional technical data are the same as for model M 2 X on page 12 of this catalogue.

All details of this Dial Gauge conform to DIN 878 in conjunction with DIN EN ISO 463. This applies not only to the dimensions but also to allowed tolerances. Spindle and stem are made of resistant stainless steel. The spindle is lapped.

Precision Dial Gauge M 2 XS shockproof	
Reading	0.01 mm
Range	10 mm
Range per revolution	1 mm
Bezel-Ø	58 mm
Stem-Ø	8 h 6
Dimensions and accuracy according to DIN EN ISO 463/DIN 878	
Initial measuring force	0.8 N
Dimensioned drawing	page 16

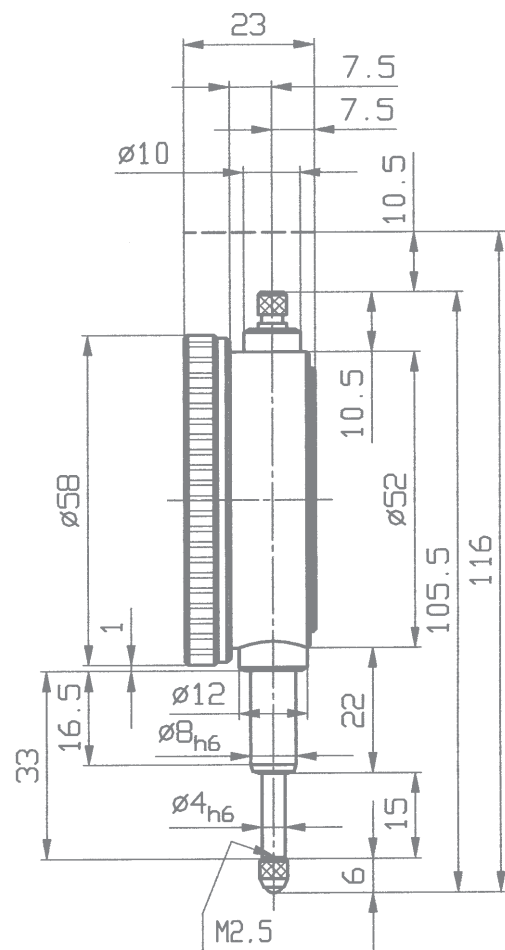

Dial Gauge M 3 S

shockproof

Due to their effective shockproof system these Dial Gauges have an exceptionally long service life. A gear rack sleeve covering the length of the spindle is arranged and sprung in such a way that shocks against the measuring insert are not transferred to the movement. The Dial Gauges are robust in operation. Their precision is maintained with practically no limitations.

Our models M 3 T and M 3 a T have exactly the same technical data, but are not shockproof.

Spindle and stem are made of resistant stainless steel. The spindle is lapped.

Precision Dial Gauge M 3 S shockproof	
Reading	0.01 mm
Range	5 mm
Range per revolution	0.5 mm
Bezel-Ø	58 mm
Stem-Ø	8 h 6
Dimensions and accuracy according to DIN EN ISO 463/DIN 878	
Initial measuring force	1.2 N
Dimensioned drawing	same as FM 1000/5 S on page 35

Dial Gauge M 3 a S

shockproof

Precision Dial Gauge M 3 a S shockproof	
Reading	0.005 mm
Range	5 mm
Range per revolution	0.5 mm
Bezel-Ø	58 mm
Stem-Ø	8 h 6
Dimensions and accuracy according to DIN EN ISO 463/DIN 878	
Initial measuring force	1.2 N
Dimensioned drawing	same as FM 1000/5 S on page 35



Dial Gauge M 2/20 T

The concentric millimetre pointer allows easy and safe reading of these Dial Gauges.

Spindle and stem are made of resistant stainless steel. The spindle is lapped.

Our models M 2/20 S and M 2/25 S have exactly the same technical data, but are shockproof.

Precision Dial Gauge M 2/20 T	
Reading	0.01 mm
Range	20 mm
Range per revolution	1 mm
Bezel-Ø	58 mm
Stem-Ø	8 h 6
Dimensions and accuracy	according to DIN EN ISO 463 / manufacturing standard 1.0200.9.0014
Initial measuring force	0.8 N
Dimensioned drawing	on request



Dial Gauge M 2/25 T

Precision Dial Gauge M 2/25 T	
Reading	0.01 mm
Range	25 mm
Range per revolution	1 mm
Bezel-Ø	58 mm
Stem-Ø	8 h 6
Dimensions and accuracy	according to DIN EN ISO 463 / manufacturing standard 1.0200.9.0014
Initial measuring force	0.8 N
Dimensioned drawing	on request



Dial Gauge M 2/30 T

The concentric millimetre pointer allows easy and safe reading of this Dial Gauge. The carefully thought-out design, the use of selected components and materials as well as the movement perfected by precision engineering guarantee reliable measuring results and a long service life of the Precision Dial Gauge M 2/30 T. The essential parts of the movement are jewelled.

Spindle and stem are made of resistant stainless steel. The spindle is lapped.



Precision Dial Gauge M 2/30 T	
Reading	0.01 mm
Range	30 mm
Range per revolution	1 mm
Bezel-Ø	58 mm
Stem-Ø	8 h 6
Dimensions and accuracy according to	DIN EN ISO 463 / manufacturing standard 1.0200.9.0014
Initial measuring force	0.8 N
Dimensioned drawing	page 20

On request the Dial Gauge M 2/30 T is also available with special fittings:

- **Dial Gauge M 2/30 T**
with fixing screw for the bezel
- **Dial Gauge M 2/30 T**
with lifting device at the back
- **Dial Gauge M 2/30 T**
with special transmission ratio
(range per revolution = 25 or 30 mm)
- **Dial Gauge M 2/30 T**
with counter clockwise dial reading
- **Dial Gauge M 2/30 T**
with balanced dial reading 0-50-0
- **Dial Gauge M 2/30 T**
with increased measuring force
- **Dial Gauge M 2/30 T**
with reduced measuring force
- **Dial Gauge M 2/30 T**
with reverse spring traction
- **Dial Gauge M 2/30 T**
with two stems: top and bottom
- **Dial Gauge M 2/30 T**
with extended stem

Dial Gauge M 2/30 S

shockproof

Except for the additional shockproof system all technical features of the Dial Gauge M 2/30 S are the same as for the M 2/30 T Dial Gauge on page 19 of this catalogue. Effective impact protection protects the Dial Gauge M 2/30 S even from hard impacts on the spindle, thereby reducing the risk of damage to the teeth.

Spindle and stem are made of resistant stainless steel. The spindle is lapped.

Precision Dial Gauge M 2/30 S shockproof

Reading	0.01 mm
Range	30 mm
Range per revolution	1 mm
Bezel-Ø	58 mm
Stem-Ø	8 h 6
Dimensions and accuracy according to	DIN EN ISO 463 / manufacturing standard 1.0200.9.0014
Initial measuring force	0.8 N
Dimensioned drawing	page 20

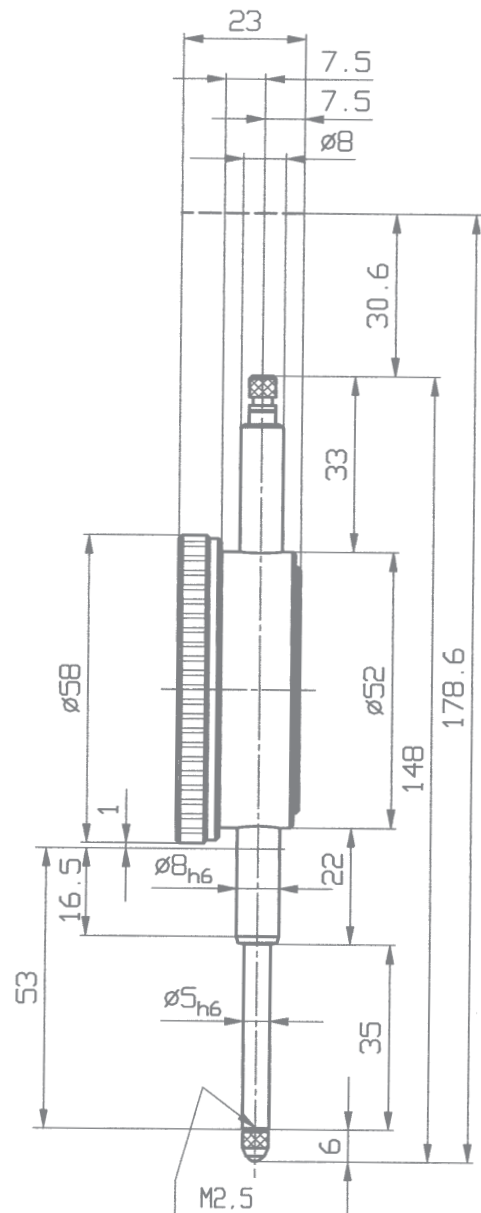

Dial Gauge MU 52/30 T

Dial Gauge MU 52/30 S

shockproof



Our new Dial Gauge Series MU 52 has been designed and manufactured by Käfer Dial Gauges Shanghai. The racks and pinions – the key parts for the accuracy of Dial Gauges – are however supplied by Käfer Germany. All Dial Gauges are checked for their accuracy on a Feinmess Suhl automatic Dial Gauge Measuring Machine.

All details of these Dial Gauges conform to DIN EN ISO 463 / manufacturing standard 1.0200.9.0014. Except for the shockproof system all technical features of the Dial Gauge MU 52/30 S are the same as for the MU 52/30 T Dial Gauge. Effective impact protection protects the Dial Gauge MU 52/30 S even from hard impacts on the spindle, thereby reducing the risk of damage of the teeth.

Precision Dial Gauge MU 52/30 T	
Reading	0.01 mm
Range	30 mm
Range per revolution	1 mm
Bezel-Ø	58 mm
Stem-Ø	8 h 6
Dimensions and accuracy according to	DIN EN ISO 463 / manufacturing standard 1.0200.9.0014
Initial measuring force	0.8 N
Dimensioned drawing	page 21

Precision Dial Gauge MU 52/30 S shockproof	
Reading	0.01 mm
Range	30 mm
Range per revolution	1 mm
Bezel-Ø	58 mm
Stem-Ø	8 h 6
Dimensions and accuracy according to	DIN EN ISO 463 / manufacturing standard 1.0200.9.0014
Initial measuring force	0.8 N
Dimensioned drawing	page 21



Model shown: MU 52/30 S

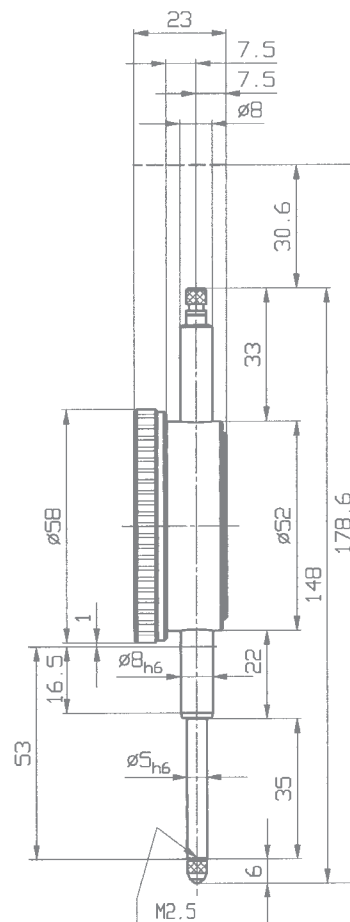

Dial Gauge M 2/50 T

Dial Gauge M 2/50 S shockproof

The concentric millimetre pointer allows easy and safe reading of these Dial Gauges. The essential parts of the movement are jewelled.

An effective shockproof gear protects the Dial Gauge M 2/50 S even from hard shocks on the spindle, therefore reducing the risk of damage to its teeth.

Spindle and stem are made of resistant stainless steel. The spindle is lapped.

Precision Dial Gauge M 2/50 T	
Reading	0.01 mm
Range	50 mm
Range per revolution	1 mm
Bezel-Ø	58 mm
Stem-Ø	8 h 6
Dimensions and accuracy according to	DIN EN ISO 463 / manufacturing standard 1.0200.9.0002
Initial measuring force	1.5 N
Dimensioned drawing	page 22

Precision Dial Gauge M 2/50 S shockproof	
Reading	0.01 mm
Range	50 mm
Range per revolution	1 mm
Bezel-Ø	58 mm
Stem-Ø	8 h 6
Dimensions and accuracy according to	DIN EN ISO 463 / manufacturing standard 1.0200.9.0002
Initial measuring force	1.5 N
Dimensioned drawing	page 22

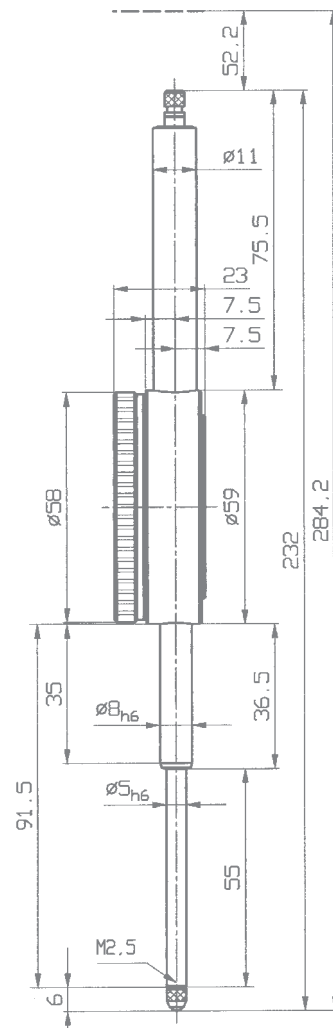

Dial Gauge M 2/80 T

Dial Gauge M 2/80 S shockproof



The concentric millimetre pointer allows easy and safe reading of these Dial Gauges. The essential parts of the movement are jewelled.

An effective shockproofed gear protects the Dial Gauge M 2/80 S even from hard shocks on the spindle, therefore reducing the risk of damage to its teeth.

Spindle and stem are made of resistant stainless steel. The spindle is lapped.

Precision Dial Gauge M 2/80 T	
Reading	0.01 mm
Range	80 mm
Range per revolution	1 mm
Bezel-Ø	58 mm
Stem-Ø	8 h 6
Dimensions and accuracy according to	DIN EN ISO 463 / manufacturing standard 1.0200.9.0002
Initial measuring force	1.5 N
Dimensioned drawing	page 23

Precision Dial Gauge M 2/80 S shockproof	
Reading	0.01 mm
Range	80 mm
Range per revolution	1 mm
Bezel-Ø	58 mm
Stem-Ø	8 h 6
Dimensions and accuracy according to	DIN EN ISO 463 / manufacturing standard 1.0200.9.0002
Initial measuring force	1.5 N
Dimensioned drawing	page 23

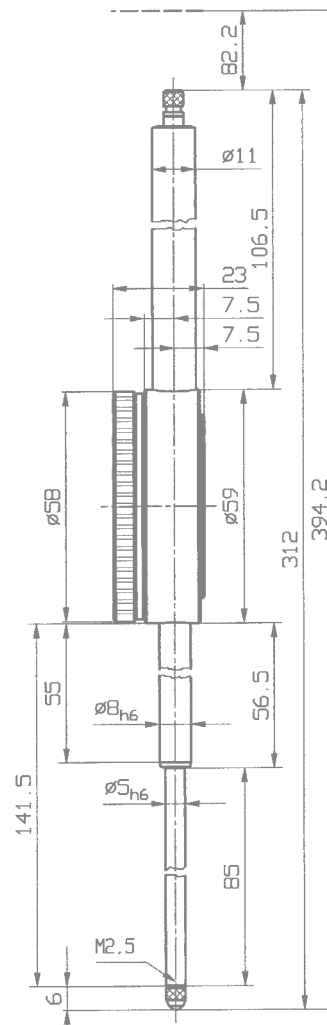

Dial Gauge GM 80/100 T

The concentric millimetre pointer allows easy and safe reading of the Dial Gauge.

In comparison with Dial Gauges having smaller measuring ranges the model GM 80/100 T has a measuring spindle \varnothing of 6 mm and a stem \varnothing of 10 mm. These features increase the stability and durability of the Dial Gauge.

Dial Gauges with 100 mm measuring range are also available in the following versions:

- bezel- \varnothing 58 mm (model M 2/100 T)
- bezel- \varnothing 100 mm (model GM 100/100 T)
- shockproof (model GM 80/100 S)
- with reading of 0.1 mm (model GM 10/100 f)



Precision Dial Gauge GM 80/100 T

Reading	0.01 mm
Range	100 mm
Range per revolution	1 mm
Bezel- \varnothing	80 mm
Stem- \varnothing	10 h 6
Dimensions and accuracy according to	DIN EN ISO 463 / manufacturing standard 1.0200.9.0002
Initial measuring force	1.2 N
Dimensioned drawing	page 24

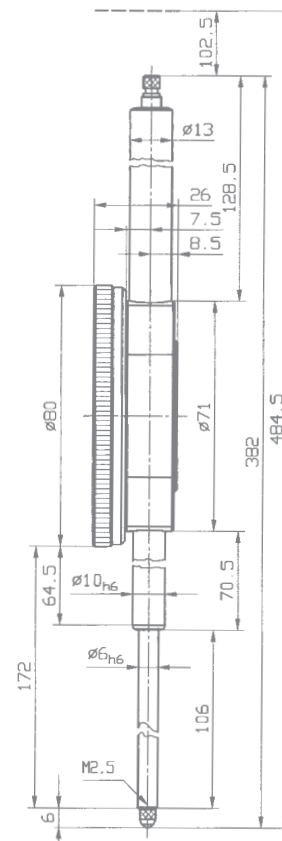

Small Dial Gauge MU 28

The Dial Gauge MU 28 is the smallest model of our broad manufacturing programme. Its extremely small overall dimensions require a special adjustment procedure according to manufacturing standards.

Spindles and stems of the Small Dial Gauges MU 28 and KM 6 T are made of resistant stainless steel.

Small Dial Gauge MU 28	
Reading	0.01 mm
Range	3.5 mm
Range per revolution	0.5 mm
Bezel-Ø	28 mm
Stem-Ø	8 h 6
Dimensions and accuracy according to	DIN EN ISO 463 / manufacturing standard 4.0000.9.0012
Initial measuring force	0.8 N
Dimensioned drawing	page 25

Small Dial Gauge KM 6 T

All allowed tolerances of the Small Dial Gauge KM 6 T conform to DIN 878.

On request the Small Dial Gauge KM 6 T is also available with special fittings:

- KM 6 T with lifting device
- KM 6 T with counter clockwise dial reading
- KM 6 T with balanced dial reading 0-25-0
- KM 6 T with increased or reduced measuring force

Small Dial Gauge KM 6 T	
Reading	0.01 mm
Range	3 mm
Range per revolution	0.5 mm
Bezel-Ø	32 mm
Stem-Ø	8 h 6
Dimensions and accuracy according to	DIN EN ISO 463/DIN 878
Initial measuring force	0.5 N
Dimensioned drawing	page 25

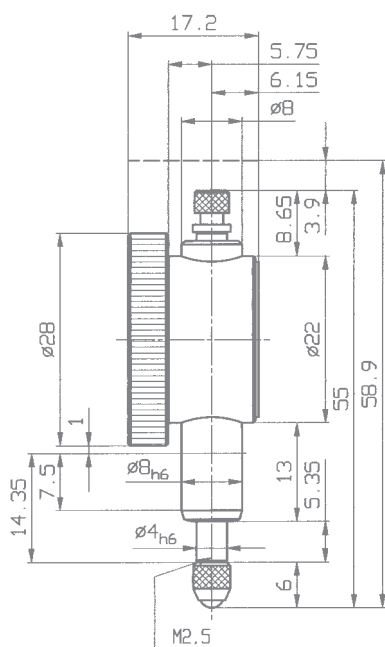

Model shown: KM 6 T

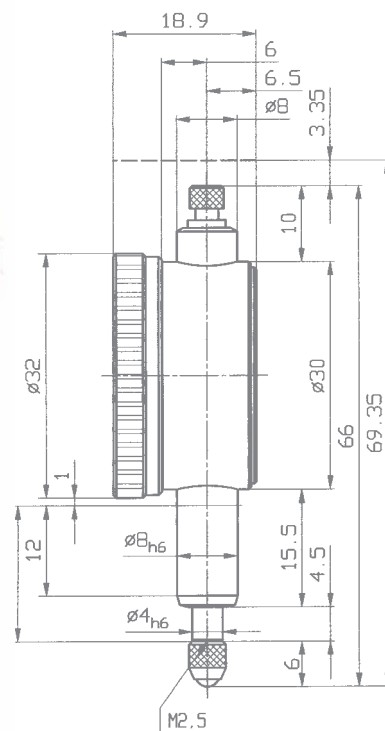

Small Dial Gauge KM 4 T

Our Small Dial Gauges have 40 mm Ø bezel. As standard they have 0.5 mm travel range per revolution and 50 graduations on the dial. This offers the advantage of a clear and easily readable Dial Gauge.

Spindle and stem are made of resistant stainless steel. The spindle is lapped.



Small Dial Gauge KM 4 T

Reading	0.01 mm
Range	3 mm
Range per revolution	0.5 mm
Bezel-Ø	40 mm
Stem-Ø	8 h 6
Dimensions and accuracy according to DIN EN ISO 463/DIN 878	
Initial measuring force	0.9 N
Dimensioned drawing	page 27

On request the Dial Gauge KM 4 T is also available with special fittings:

- **Small Dial Gauge KM 4 T**
with fixing screw for the bezel
- **Small Dial Gauge KM 4 T**
with lifting device
- **Small Dial Gauge KM 4 T**
with special transmission ratio
(range per revolution = 1 mm)
- **Small Dial Gauge KM 4 T**
with counter clockwise reading
- **Small Dial Gauge KM 4 T**
with balanced dial reading 0-25-0
- **Small Dial Gauge KM 4 T**
with increased measuring force
- **Small Dial Gauge KM 4 T**
with reduced measuring force
- **Small Dial Gauge KM 4 T**
with reverse spring traction
- **Small Dial Gauge KM 4 T**
with extended stem

Model KM 4/5 T illustrated on the opposite page can also be manufactured according to the above listed versions.

Small Dial Gauge KM 4/5 T

Except for the longer measuring range all technical features of Small Dial Gauge KM 4/5 T are the same as for model KM 4 T.

All details of this Small Dial Gauge conform to DIN EN ISO 463 / DIN 878. This applies not only to the outside dimensions but also to allowed tolerances, the measuring force and the measuring force reversal range.

Spindle and stem are made of resistant stainless steel. The spindle is lapped.

Small Dial Gauge KM 4/5 T	
Reading	0.01 mm
Range	5 mm
Range per revolution	0.5 mm
Bezel-Ø	40 mm
Stem-Ø	8 h 6
Dimensions and accuracy according to DIN EN ISO 463/DIN 878	
Initial measuring force	0.9 N
Dimensioned drawing	page 27

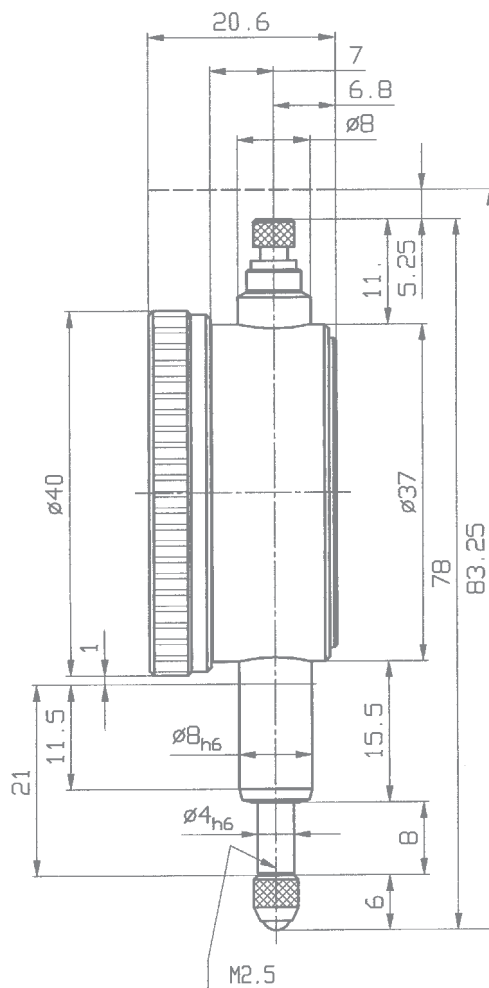

On the Small Dial Gauge KM 4 T the dimensions of 83.25 and 5.25 have to be decreased to 81.25 and 3.25.

Small Dial Gauges KM 4/5 T – 100 and KM 4/10 TK – 100

1 pointer revolution = 1 mm

Apart from our standard Small Dial Gauges, which have a pointer revolution of 0.5 mm, the models illustrated on this page have 1 mm per revolution and 100 graduations on the dial.

Model KM 4/10 TK – 100 offers with 10 mm the longest range of our broad manufacturing programme of Small Dial Gauges. The concentric millimetre pointer allows easy and safe reading of this Small Dial Gauge.

All details of these Dial Gauges conform to DIN EN ISO 463 / DIN 878. This applies not only to the dimensions but also to allowed tolerances

Small Dial Gauge KM 4/5 T-100	
Reading	0.01 mm
Range	5 mm
Range per revolution	1 mm
Bezel-Ø	40 mm
Stem-Ø	8 h 6
Dimensions and accuracy according to DIN EN ISO 463/DIN 878	
Initial measuring force	0.9 N
Dimensioned drawing	page 27

Small Dial Gauge KM 4/10 TK-100	
Reading	0.01 mm
Range	10 mm
Range per revolution	1 mm
Bezel-Ø	40 mm
Stem-Ø	8 h 6
Dimensions and accuracy according to DIN EN ISO 463/DIN 878	
Initial measuring force	0.7 N
Dimensioned drawing	page 29

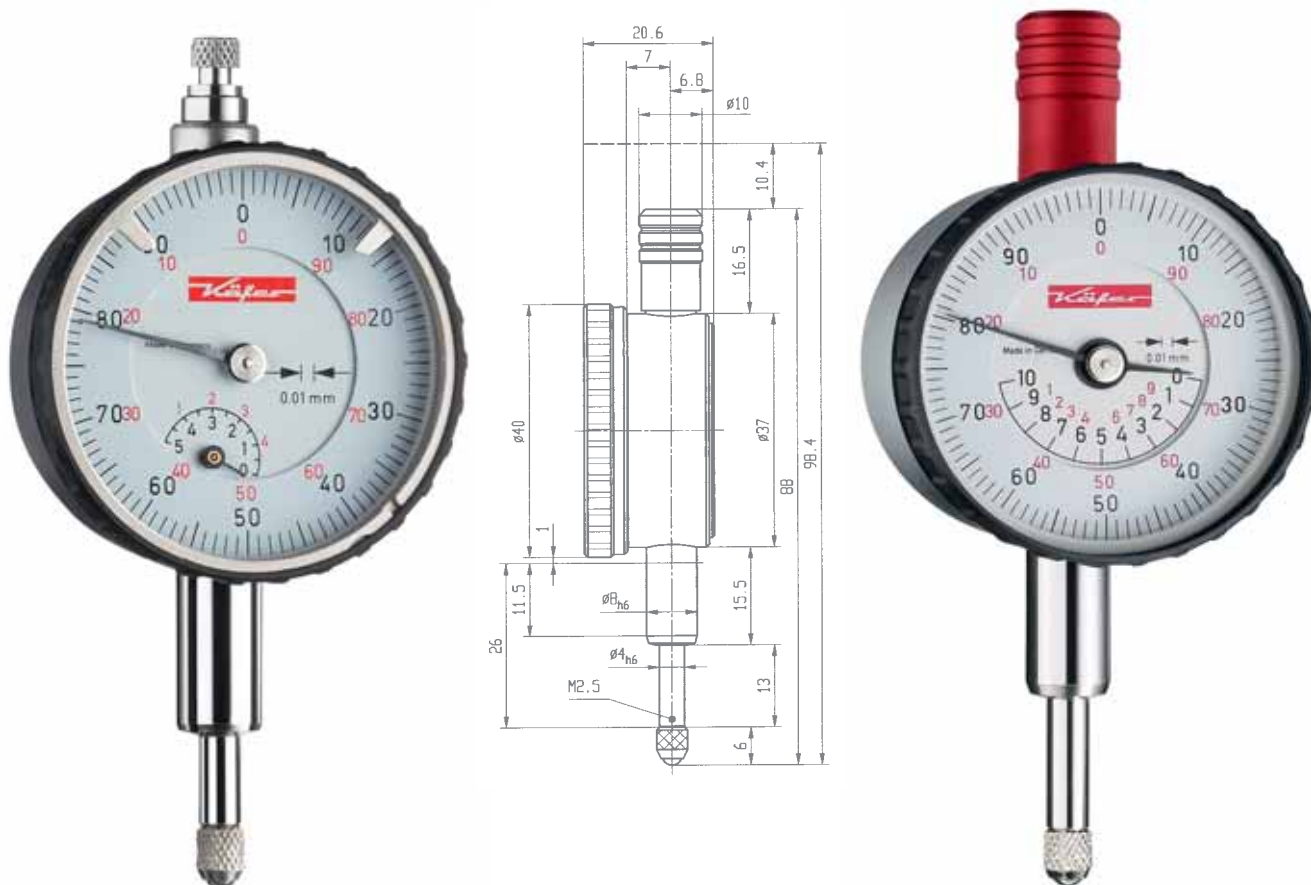

Small Dial Gauge KM 4 S

shockproof

The high-class impact protection of the Small Dial Gauge KM 4 S results in an exceptionally long service life. A gear rack sleeve covering the length of the spindle is arranged and sprung in such a way that the shocks against the measuring insert are not transferred to the measuring gear. The Small Dial Gauge is robust in operation. Its precision is maintained with practically no limitations.

Spindle and stem are made of resistant stainless steel. The spindle is lapped.



Small Dial Gauge KM 4 S shockproof

Reading	0.01 mm
Range	3 mm
Range per revolution	0.5 mm
Bezel-Ø	40 mm
Stem-Ø	8 h 6
Dimensions and accuracy according to DIN EN ISO 463/DIN 878	
Initial measuring force	1 N
Dimensioned drawing	on request

On request the Dial Gauge KM 4 S is also available with special fittings:

- **Small Dial Gauge KM 4 S**
with fixing screw for the bezel
- **Small Dial Gauge KM 4 S**
with lifting device
- **Small Dial Gauge KM 4 S**
with threaded protective sleeve
- **Small Dial Gauge KM 4 S**
with special transmission ratio
range per revolution = 1 mm
- **Small Dial Gauge KM 4 S**
with counter clockwise reading
- **Small Dial Gauge KM 4 S**
with balanced dial reading 0-25-0
- **Small Dial Gauge KM 4 S**
with increased measuring force
- **Small Dial Gauge KM 4 S**
with reduced measuring force
- **Small Dial Gauge KM 4 S**
with extended stem
(length from casing 29.5 mm)

Model KM 4/5 S illustrated on the opposite page can also be manufactured according to the above listed versions.

Small Dial Gauge KM 4/5 S

shockproof

Except for the longer measuring range all technical features of the Small Dial Gauge KM 4/5 S are the same as for model KM 4 S.

All details of this Small Dial Gauge conform to DIN EN ISO 463 / DIN 878. This applies not only to the outside dimensions but also to allowed tolerances.

Spindle and stem are made of resistant stainless steel. The spindle is lapped.

Small Dial Gauge KM 4/5 S shockproof	
Reading	0.01 mm
Range	5 mm
Range per revolution	0.5 mm
Bezel-Ø	40 mm
Stem-Ø	8 h 6
Dimensions and accuracy according to DIN EN ISO 463/DIN 878	
Initial measuring force	1 N
Dimensioned drawing	page 31

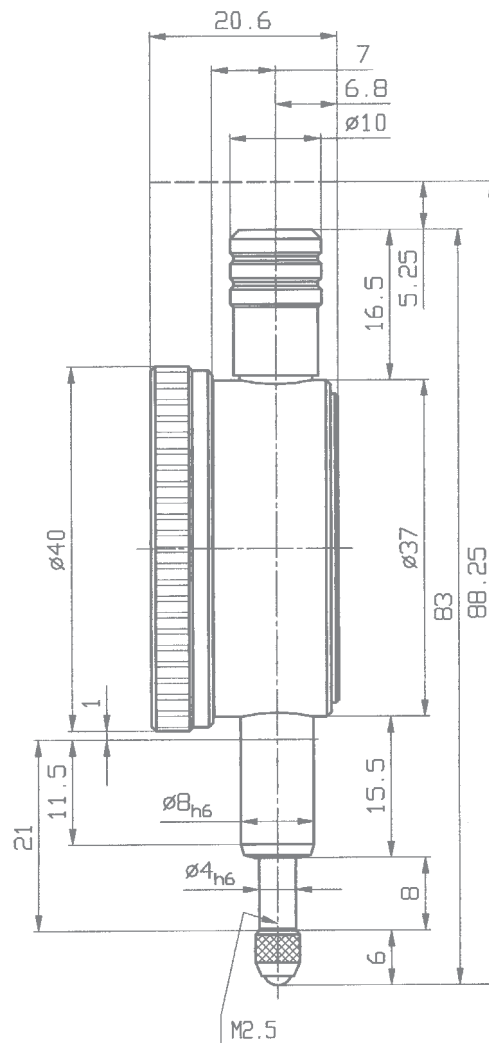

Dial Gauge GM 80 S

shockproof

The high-class impact protection of the Dial Gauge GM 80 S results in an exceptionally long service life. A gear rack sleeve covering the length of the spindle is arranged and sprung in such a way that the shocks against the measuring insert are not transferred to the measuring gear. The Dial Gauge is robust in operation. Its precision is maintained with practically no limitations.

Spindle and stem are made of resistant stainless steel. The spindle is lapped.

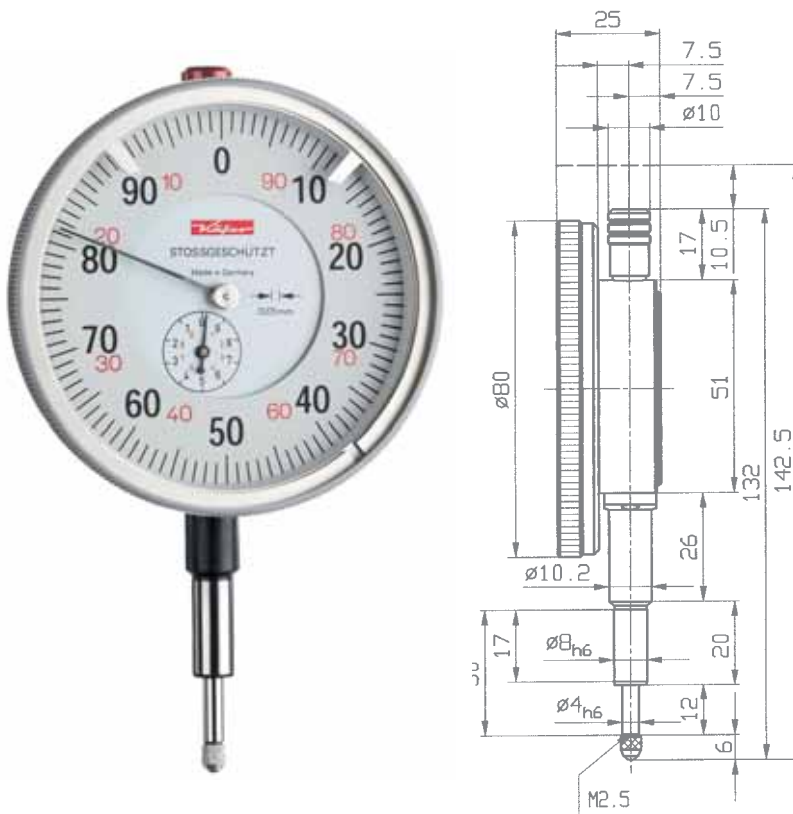

Dial Gauge GM 80 S shockproof	
Reading	0.01 mm
Range	10 mm
Range per revolution	1 mm
Bezel-Ø	80 mm
Stem-Ø	8 h 6
Dimensions and accuracy according to DIN EN ISO 463 / manufacturing standard 0.0200.9.0016	
Initial measuring force	1 N
Dimensioned drawing	page 32

Other Dial Gauges with large bezel diameter from our production range:

Dial Gauge GM 80 T	
Reading	0.01 mm
Range	10 mm
Range per revolution	1 mm
Bezel-Ø	80 mm
Stem-Ø	8 h 6
Dimensions and accuracy according to DIN EN ISO 463 / manufacturing standard 0.0200.9.0016	
Initial measuring force	1 N
Dimensioned drawing	on request

Dial Gauge GM 100 T	
Reading	0.01 mm
Range	10 mm
Range per revolution	1 mm
Bezel-Ø	100 mm
Stem-Ø	8 h 6
Dimensions and accuracy according to DIN EN ISO 463 / manufacturing standard 0.0200.9.0016	
Initial measuring force	1 N
Dimensioned drawing	on request

Dial Gauge GM 100 S shockproof	
Reading	0.01 mm
Range	10 mm
Range per revolution	1 mm
Bezel-Ø	100 mm
Stem-Ø	8 h 6
Dimensions and accuracy according to DIN EN ISO 463 / manufacturing standard 0.0200.9.0016	
Initial measuring force	1 N
Dimensioned drawing	on request