

High Precision Dial Gauges

Our High Precision Dial Gauges are high-resolution gauges with 0.001 mm or 0.002 mm graduations and 0.1 mm or 0.2 mm measuring distance per pointer revolution. The high magnification gear train and high-resolution dials allow a very precise reading of the measured value.

The well thought-out design as well as the extremely precise, while robust in operation, execution of our High Precision Dial Gauges with precision gear movement guarantee for their reliability and long service life. The following quality features apply to our entire manufacturing programme:

- Highly responsive movements.
- Precisely matched measuring spindles and stems to minimise lateral play.
- All gear pivots run in high-class ruby bearings.
- Lifting cap to raise the plunger easily and to prevent ingress of contaminants.
- All waterproof and water protected models have a threaded protection sleeve to prevent ingress of contaminants.

- All shockproof models contain an effective impact protection sleeve.
- Dimensions according to DIN EN ISO 463 (except waterproof and waterprotected models)

As standard High Precision Dial Gauges are manufactured with measuring ranges up to 5 mm. However the gear movements can accommodate ranges up to 10 mm. Please contact us if you require longer measuring ranges.

DIN 878 does not include these High Precision Dial Gauges. They are subject to a strict manufacturing standard.

For the High Precision Dial Gauges with precision gear movements listed in the following table our works standard 0.0500.9.0001 applies.

Please see pages 38 – 40 for our series ‚FEINIKA‘ High Precision Dial Gauges.

Technical data for Metric High Precision Dial Gauges with gear movement

Model	Reading	Range per revolution	Range	Overtravel	Bezel-Ø	Special Feature
KM 500 T	0.002 mm	0.2 mm	1 mm	–	40 mm	
KM 500 S	0.002 mm	0.2 mm	1 mm	–	40 mm	Shockproof
KM 500/3 S	0.002 mm	0.2 mm	3 mm	–	40 mm	Shockproof
KM 500 SW	0.002 mm	0.2 mm	1 mm	–	44.5 mm	Waterproof
FM 500 T	0.002 mm	0.2 mm	1 mm	–	58 mm	
FM 500 SI	0.002 mm	–	0.16 mm	5 mm	58 mm	Error Free
KM 1000 T	0.001 mm	0.2 mm	1 mm	–	40 mm	
KM 1000 S	0.001 mm	0.2 mm	1 mm	–	40 mm	Shockproof
FM 1000 T	0.001 mm	0.2 mm	1 mm	–	58 mm	
FM 1000 S	0.001 mm	0.2 mm	1 mm	4 mm	58 mm	Shockproof
FM 1000/5 T	0.001 mm	0.2 mm	5 mm	–	58 mm	
FM 1000/5 S	0.001 mm	0.2 mm	5 mm	–	58 mm	Shockproof
SI-180	0.001 mm	–	0.16 mm	5 mm	58 mm	Error Free
FM 1000 S wa	0.001 mm	0.2 mm	1 mm	4 mm	58 mm	Water Protected
FM 1000 SW	0.001 mm	0.2 mm	1 mm	4 mm	61.5 mm	Waterproof
FM 1000/5 SW	0.001 mm	0.2 mm	5 mm	–	61.5 mm	Waterproof
FM 1000/80 T	0.001 mm	0.2 mm	1 mm	–	80 mm	
FM 1000/80 S	0.001 mm	0.2 mm	1 mm	4 mm	80 mm	Shockproof
FM 1000/80-5 T	0.001 mm	0.2 mm	5 mm	–	80 mm	
FM 1000/80-5 S	0.001 mm	0.2 mm	5 mm	–	80 mm	Shockproof

Small Dial Gauge KM 500 S

shockproof

Small Dial Gauge KM 1000 S

shockproof

The High Precision Small Dial Gauges KM 500 S and KM 1000 S equipped with a high-class impact protection have an extremely long service life. A gear rack sleeve covering the length of the spindle is arranged and sprung in such a way that the shocks against the measuring insert are not transferred to the measuring gear. The Small Dial Gauges are robust in operation. Their precision is maintained with practically no limitations.

Spindle and stem are made of resistant stainless steel. The spindle is lapped.

High Precision Dial Gauge KM 500 S shockproof	
Reading	0.002 mm
Range	1 mm
Range per revolution	0.2 mm
Bezel-Ø	40 mm
Stem-Ø	8 h 6
Dimensions and accuracy according to	DIN EN ISO 463 / manufacturing standard 0.0500.9.0001
Initial measuring force	1 N
Dimensioned drawing	page 34

High Precision Dial Gauge KM 1000 S shockproof	
Reading	0.001 mm
Range	1 mm
Range per revolution	0.2 mm
Bezel-Ø	40 mm
Stem-Ø	8 h 6
Dimensions and accuracy according to	DIN EN ISO 463 / manufacturing standard 0.0500.9.0001
Initial measuring force	1 N
Dimensioned drawing	page 34



Model shown: KM 500 S

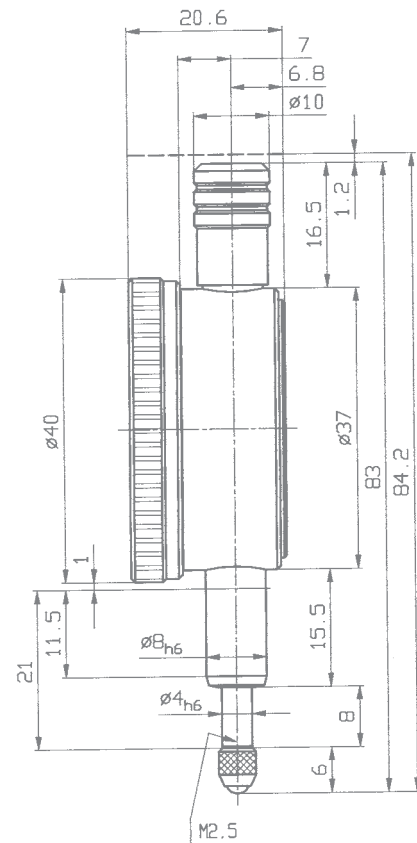

Dial Gauge FM 1000/5 S

shockproof

Except for the longer measuring range and the bezel diameter of 58 mm all technical features of Dial Gauge FM 1000/5 S are the same as for model KM 1000 S.

Spindle and stem are made of resistant stainless steel. The spindle is lapped.

We manufacture also High Precision Dial Gauges with a bezel \varnothing of 80 mm. The model FM 1000/80-5 S has the same technical data as the model FM 1000/5 S, but a bezel diameter of 80 mm.

High Precision Dial Gauge FM 1000/5 S shockproof

Reading	0.001 mm
Range	5 mm
Range per revolution	0.2 mm
Bezel- \varnothing	58 mm
Stem- \varnothing	8 h 6
Dimensions and accuracy according to	DIN EN ISO 463 / manufacturing standard 0.0500.9.0001
Initial measuring force	1.2 N
Dimensioned drawing	page 35

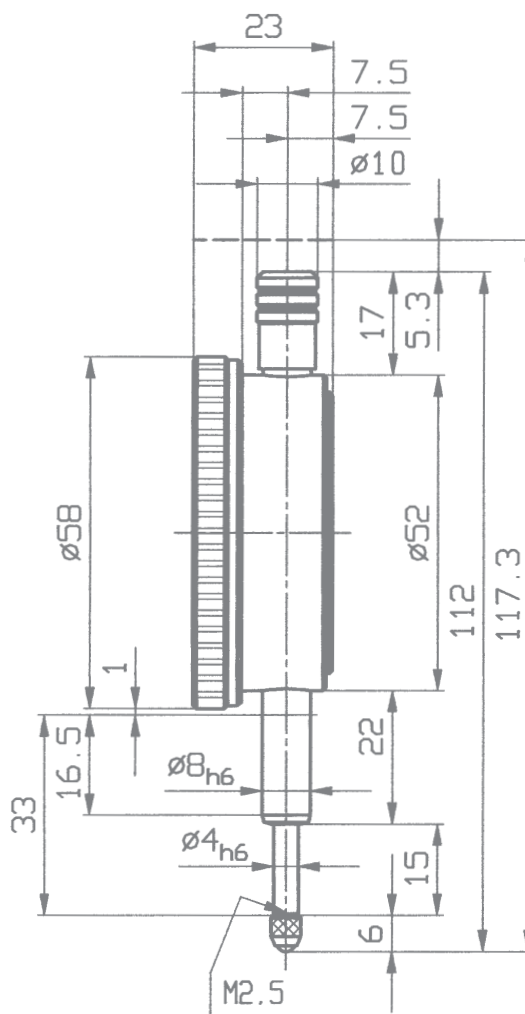

Dial Gauge FM 1000 T

Dial Gauge FM 500 T

The only difference between FM 1000 T and FM 500 T is the number of graduations on the dial face. FM 1000 T has 200 graduations, each of 0.001 mm, whereas FM 500 T has 100 graduations of 0.002 mm.

Spindle and stem are made of resistant stainless steel. The spindle is lapped.

High Precision Dial Gauge FM 1000 T	
Reading	0.001 mm
Range	1 mm
Range per revolution	0.2 mm
Bezel-Ø	58 mm
Stem-Ø	8 h 6
Dimensions and accuracy according to	DIN EN ISO 463 / manufacturing standard 0.0500.9.0001
Initial measuring force	1.5 N
Dimensioned drawing	page 36

High Precision Dial Gauge FM 500 T	
Reading	0.002 mm
Range	1 mm
Range per revolution	0.2 mm
Bezel-Ø	58 mm
Stem-Ø	8 h 6
Dimensions and accuracy according to	DIN EN ISO 463 / manufacturing standard 0.0500.9.0001
Initial measuring force	1.5 N
Dimensioned drawing	page 36



Model shown: FM 1000 T

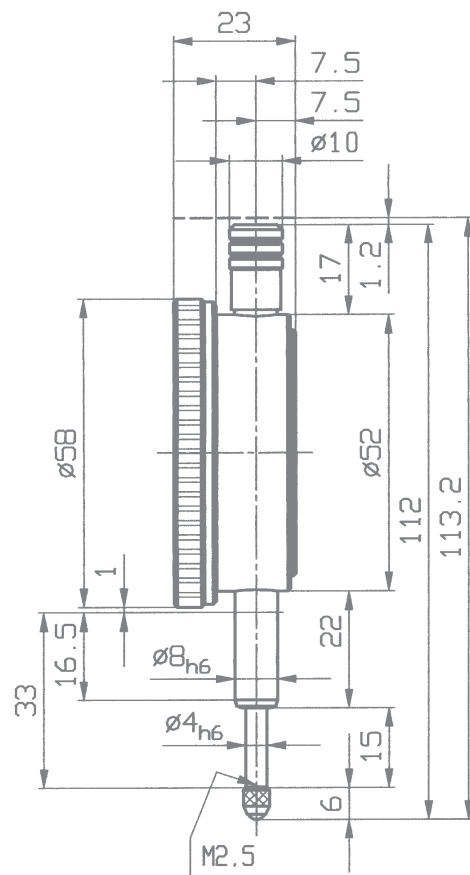

Dial Gauge FM 1000/5 T

The carefully thought-out design, the use of selected components and materials as well as the movement perfected by precision engineering guarantee reliable measuring results and a long service life of our Precision Dial Gauges.

Spindle and stem are made of resistant stainless steel. The spindle is lapped.

High Precision Dial Gauge FM 1000/5 T	
Reading	0.001 mm
Range	5 mm
Range per revolution	0.2 mm
Bezel-Ø	58 mm
Stem-Ø	8 h 6
Dimensions and accuracy according to	DIN EN ISO 463 / manufacturing standard 0.0500.9.0001
Spindle	lapped
Dimensioned drawing	on request



On request the Dial Gauges FM 1000 T and FM 1000/5 T are also available with special fittings:

- **FM 1000 T resp. FM 1000/5 T** with fixing screw for the bezel
- **FM 1000 T resp. FM 1000/5 T** with lifting device
- **FM 1000 T resp. FM 1000/5 T** with wire release
- **FM 1000 T resp. FM 1000/5 T** with threaded protective sleeve
- **FM 1000 T resp. FM 1000/5 T** with special transmission ratio (range per revolution = 0.25 mm)
- **FM 1000 T resp. FM 1000/5 T** with counter clockwise dial reading
- **FM 1000 T resp. FM 1000/5 T** with increased measuring force
- **FM 1000 T resp. FM 1000/5 T** with reduced measuring force
- **FM 1000 T resp. FM 1000/5 T** with reverse spring traction
- **FM 1000 T resp. FM 1000/5 T** with extended stem



High Precision Dial Gauges with the movement of Comparator Gauges

The FEINIKA High Precision Dial Gauges have similar movements to those of our range of COMPIKA Comparator Gauges. The travel of the plunger is transmitted and magnified by means of a lever device to the hand. This lever transmission has two advantages. It provides extremely high accuracy, as well as an effective shockproof system.

The following quality features apply to our entire manufacturing programme of FEINIKA High Precision Dial Gauges:

- Effective shockproof system.
- With metal bezel.
- Lifting cap to raise the plunger easily.
- All waterproof models have a threaded protection sleeve to prevent ingress of contaminants.

- Dimensions according to DIN EN ISO 463 (except waterproof models).
- Hardened plunger to protect against damage.
- Additional over-travel for easy insertion of test pieces under the measuring tip.
- Highly responsive movements.
- Precisely matched plunger and stem to minimise lateral play.
- All gear pivots run in high-class ruby bearings.
- A lifting cap to prevent ingress of contaminants.

DIN 878 does not include these High Precision Dial Gauges. So we subject these gauges to more stringent standards as laid down in the table 0.0500.9.0010 of our manufacturing standard.

Technical data for Metric High Precision Dial Gauges of the series Feinika

Model	Reading	Range per revolution	Range	Overtravel	Bezel-Ø	Special Feature
Feinika KM 1102	0.002 mm	0.1 mm	1 mm	2.5 mm	40 mm	Shockproof
Feinika FM 1102	0.002 mm	0.1 mm	1 mm	4 mm	58 mm	Shockproof
Feinika KM 1101	0.001 mm	0.1 mm	1 mm	2.5 mm	40 mm	Shockproof
Feinika KM 1101 W	0.001 mm	0.1 mm	1 mm	2.5 mm	44.5 mm	Waterproof
Feinika SI-914	0.001 mm	–	0.08 mm	3 mm	40 mm	Error Free
Feinika SI-910	0.001 mm	–	0.1 mm	3 mm	40 mm	Error Free
Feinika FM 1101	0.001 mm	0.1 mm	1 mm	4 mm	58 mm	Shockproof
Feinika FM 1101 W	0.001 mm	0.1 mm	1 mm	4 mm	61.5 mm	Waterproof
Feinika SI-915	0.001 mm	–	0.08 mm	5 mm	58 mm	Error Free
Feinika SI-916	0.001 mm	–	0.1 mm	5 mm	58 mm	Error Free
Feinika SI-918	0.001 mm	–	0.16 mm	5 mm	58 mm	Error Free

Small Dial Gauge Feinika KM 1101

shockproof

High Precision Dial Gauges Feinika have a scale with 100 graduations for one pointer revolution of 0.1 mm. This enables very precise read-off results.

The travel of the plunger is transmitted by means of a lever device to the hand. This lever transmission of the movement has two advantages. It provides extremely high accuracy, as well as an effective shockproof system.

Spindle and stem are made of resistant stainless steel. The spindle is lapped.

Small Dial Gauge Feinika KM 1101 shockproof

Reading	0.001 mm
Range	1 mm
Range per revolution	0.1 mm
Bezel-Ø	40 mm
Stem-Ø	8 h 6
Dimensions and accuracy according to	DIN EN ISO 463 / manufacturing standard 0.0500.9.0010
Initial measuring force	1 N
Dimensioned drawing	page 39

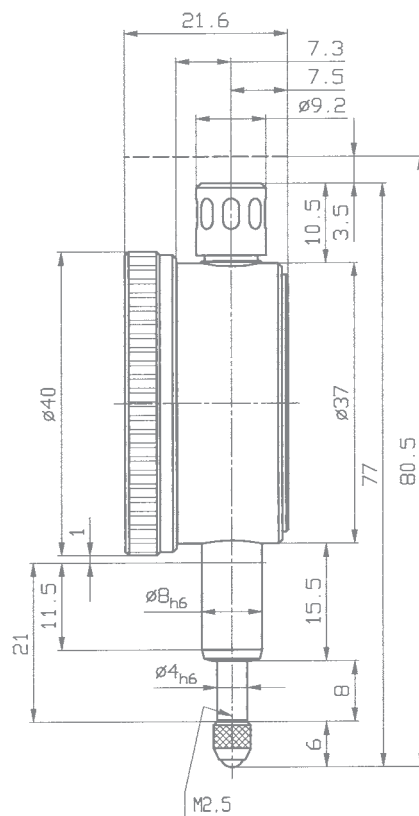

Dial Gauge Feinika FM 1101

shockproof

The travel of the plunger is transmitted by means of a lever device to the hand. This lever transmission of the movement has two advantages. It provides extremely high accuracy, as well as an effective shockproof system.

Spindle and stem are made of resistant stainless steel. The spindle is lapped.

High Precision Dial Gauges of the Feinika series are also available in waterproof version and also as Error Free Dial Gauges.



Dial Gauge Feinika FM 1101 shockproof

Reading	0.001 mm
Range	1 mm
Range per revolution	0.1 mm
Bezel-Ø	58 mm
Stem-Ø	8 h 6
Dimensions and accuracy according to	DIN EN ISO 463 / manufacturing standard 0.0500.9.0010
Initial measuring force	1.5 N
Dimensioned drawing	page 40

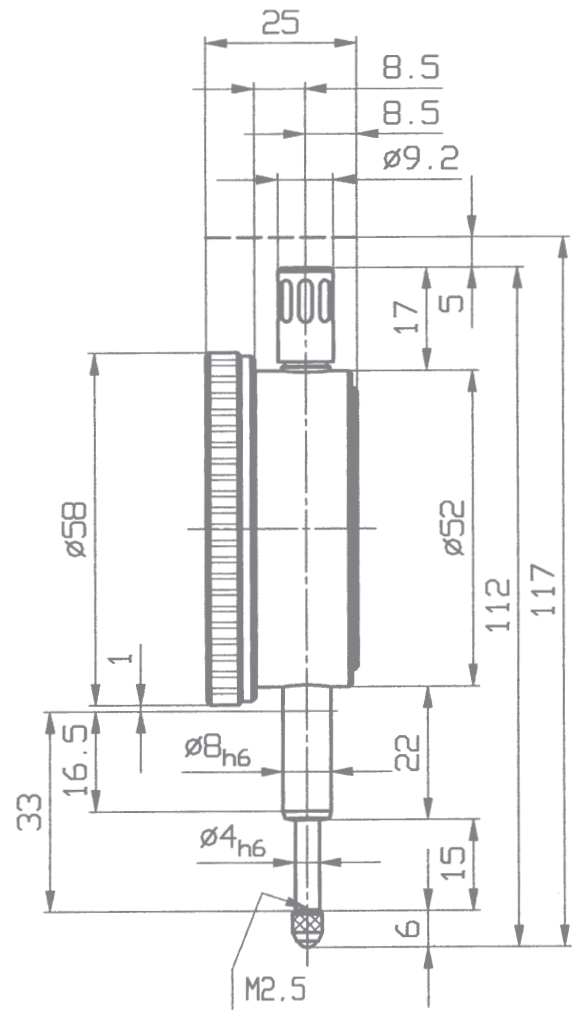

Dial Gauges with 0.1 mm reading

Dial Gauges with 0.1 mm graduations are supplied without tolerance pointers as standard. On request they can be supplied with tolerance pointers at no extra charge.

Because of the rather course transmission ratio effective on Dial Gauges with a reading of 0.1 mm the danger of damage to the gearing through shocks received by the spindle is considerably minimised. In this range we only offer Standard Dial Gauges without impact protection. Offers for Dial Gauges with a reading of 0.1 mm and shockproof are available on request.

These 0.1 mm reading Gauges are also available in waterproof and back-plunger versions. Please contact us for price and availability.

On Dial Gauges KM 5 a, KM 10 a and M 10 a one revolution of the pointer corresponds to the entire measuring range. For this reason they are specially suitable for applications benefiting from a slave pointer. A functional description of Dial Gauges with slave pointers is given on page 75 of the catalogue.

The carefully thought-out design as well as the operationally robust execution of our Dial Gauges with a reading of 0.1 mm guarantee reliable measuring results and a long service life.

Dial Gauges with a reading of 0.1 mm are not included in DIN 878. They are subject to a strict manufacturing standard. For the models listed in the following table our manufacturing standard 0.0100.9.0004 applies. Their dimensions are according to DIN EN ISO 463 (exception: Length L_2 with model M 10 d).

Technical data for Dial Gauges with 0.1 mm reading

Model	Reading	Range per revolution	Range	Bezel-Ø	Initial measuring force	Special Feature
KM 5 a	0.1 mm	5 mm	5 mm	40 mm	0.7 N	
KM 10 a	0.1 mm	10 mm	10 mm	40 mm	1.0 N	
KM 5 a R	0.1 mm	5 mm	5 mm	40 mm	1.5 N	Back Plunger
M 10 a	0.1 mm	10 mm	10 mm	58 mm	0.7 N	
M 10 b	0.1 mm	10 mm	20 mm	58 mm	0.7 N	
M 10 c	0.1 mm	10 mm	30 mm	58 mm	0.8 N	Linear display to indicate revolution
M 10 d	0.1 mm	10 mm	50 mm	58 mm	1.2 N	
SI-9/0.1	0.1 mm	–	8 mm	58 mm	0.7 N	Error Free
M 10/5 R	0.1 mm	5 mm	5 mm	58 mm	1.5 N	Back Plunger
GM 10/80	0.1 mm	10 mm	20 mm	80 mm	0.7 N	
GM 10/100	0.1 mm	10 mm	10 mm	100 mm	0.7 N	

Small Dial Gauges KM 5 a and KM 10 a

On request the Small Dial Gauges KM 5 a and KM 10 a are also available with special fittings:

- **KM 5 a resp. KM 10 a**
with lifting lever
- **KM 5 a resp. KM 10 a**
with counter clockwise dial reading
- **KM 5 a resp. KM 10 a**
with increased measuring force
- **KM 5 a resp. KM 10 a**
with reverse spring traction
- **KM 5 a resp. KM 10 a**
with tolerance indicators
- **KM 5 a resp. KM 10 a**
with extended stem

Spindle and stem are made of resistant stainless steel. The spindle is lapped.



Model shown: KM 10 a

Small Dial Gauge KM 5 a	
Reading	0.1 mm
Range	5 mm
Range per revolution	5 mm
Bezel-Ø	40 mm
Stem-Ø	8 h 6
Dimensions and accuracy according to	DIN EN ISO 463 / manufacturing standard 0.0100.9.0004
Dimensioned drawing	on request

Small Dial Gauge KM 10 a	
Reading	0.1 mm
Range	10 mm
Range per revolution	10 mm
Bezel-Ø	40 mm
Stem-Ø	8 h 6
Dimensions and accuracy according to	DIN EN ISO 463 / manufacturing standard 0.0100.9.0004
Dimensioned drawing	page 42

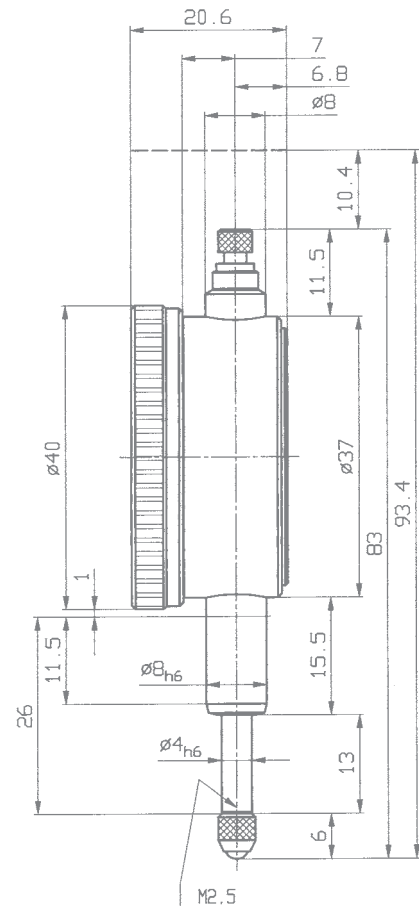

Dial Gauges M 10 a and M 10 b

The Dial Gauges with graduations of 0.1 mm have no tolerance indicators. If anyway desired they are available at no extra charge.

Dial Gauges M 10 a and M 10 b possess a stem which is laterally offset by 3.5 mm.

Spindle and stem are made of resistant stainless steel. The spindle is lapped.

In comparison to model M 10 a the Dial Gauge M 10 b has an additional revolution counter.

Dial Gauge M 10 a	
Reading	0.1 mm
Range	10 mm
Range per revolution	10 mm
Bezel-Ø	58 mm
Stem-Ø	8 h 6
Dimensions and accuracy according to	DIN EN ISO 463 / manufacturing standard 0.0100.9.0004
Dimensioned drawing	page 43

Dial Gauge M 10 b	
Reading	0.1 mm
Range	20 mm
Range per revolution	10 mm
Bezel-Ø	58 mm
Stem-Ø	8 h 6
Dimensions and accuracy according to	DIN EN ISO 463 / manufacturing standard 0.0100.9.0004
Dimensioned drawing	on request



Model shown: M 10 a

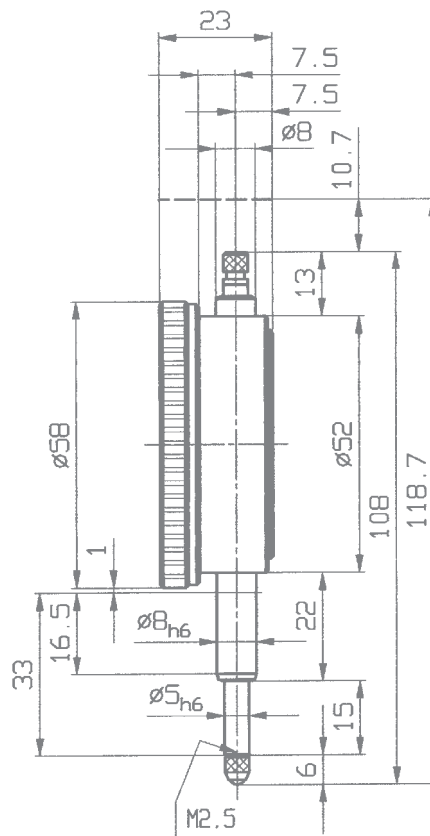

Dial Gauges M 10 c and M 10 d

On model M 10 c a straight line display is used as revolution counter instead of the traditional rotating pointer.

Dial Gauges M 10 c and M 10 d possess a stem which is laterally offset by 3.5 mm.

Spindle and stem are made of resistant stainless steel. The spindle is lapped.

In comparison to model M 10 c the Dial Gauge M 10 d has a rotating pointer as revolution counter.



Model shown: M 10 c

Dial Gauge M 10 c	
Reading	0.1 mm
Range	30 mm
Range per revolution	10 mm
Bezel-Ø	58 mm
Stem-Ø	8 h 6
Dimensions and accuracy according to	DIN EN ISO 463 / manufacturing standard 0.0100.9.0004
Dimensioned drawing	page 44

Dial Gauge M 10 d	
Reading	0.1 mm
Range	50 mm
Range per revolution	10 mm
Bezel-Ø	58 mm
Stem-Ø	8 h 6
Dimensions and accuracy according to	DIN EN ISO 463 / manufacturing standard 0.0100.9.0004
Dimensioned drawing	on request

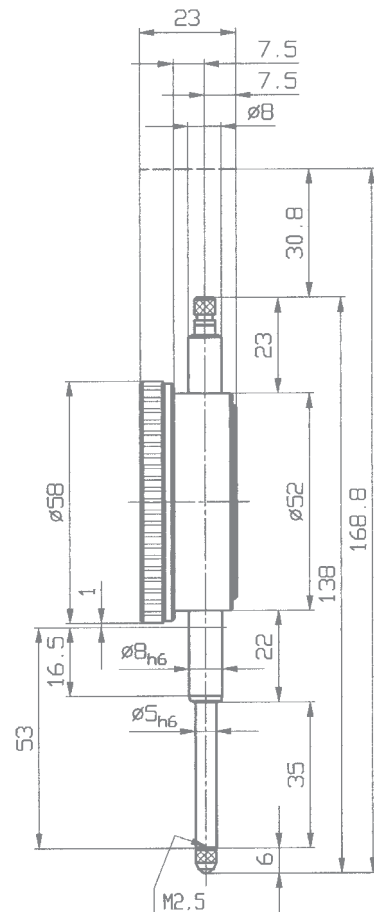

Small Dial Gauge KM 4 R with back plunger

The models KM 4 R and KM 4/5 R differ only in their measuring ranges. Both Dial Gauges can be held either on the standard 8 mm h 6 stem or on the 28 mm diameter spigot.

Spindle and stem are made of resistant stainless steel. The spindle is lapped.

Small Dial Gauge KM 4/5 R with back plunger

Small Dial Gauge KM 4 R with back plunger	
Reading	0.01 mm
Range	3 mm
Range per revolution	0.5 mm
Bezel-Ø	40 mm
Stem-Ø	8 h 6
Dimensions and accuracy according to	DIN EN ISO 463 / manufacturing standard 0.0500.9.0006
Initial measuring force	1 N
Dimensioned drawing	page 45

Small Dial Gauge KM 4/5 R with back plunger	
Reading	0.01 mm
Range	5 mm
Range per revolution	0.5 mm
Bezel-Ø	40 mm
Stem-Ø	8 h 6
Dimensions and accuracy according to	DIN EN ISO 463 / manufacturing standard 0.0500.9.0006
Initial measuring force	0.9 N
Dimensioned drawing	page 45



Model shown: KM 4 R

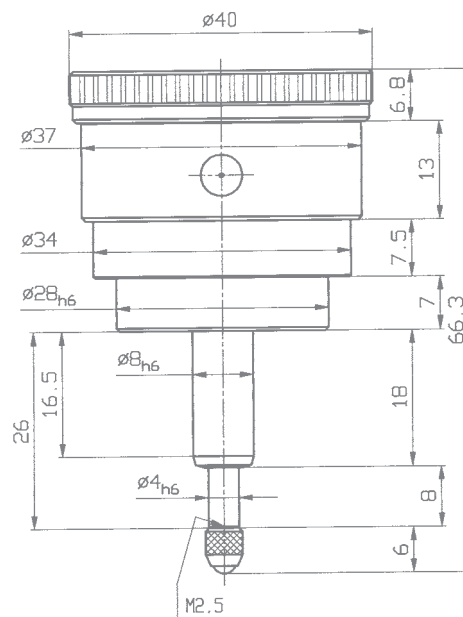

On the Small Dial Gauge KM 4/5 R the dimension of 7.5 mm in the above dimensioned drawing has been increased to 9.5 mm and the overall length from 66.3 mm to 68.3 mm.

Technical data for other Small Dial Gauges with back plunger

Model	Reading	Range	Dial Numbering	Bezel Ø	Dimensions and accuracy according to
KM 5 a R	0.1 mm	5 mm	0 – 5	40 mm	DIN EN ISO 463 / manufacturing standard 0.0100.9.0004
SI-45 R	0.01 mm	0.4 mm	20 – 0 – 20	40 mm	DIN EN ISO 463 / manufacturing standard 0.0500.9.0006
SI-45/0.8 R	0.01 mm	0.8 mm	40 – 0 – 40	40 mm	DIN EN ISO 463 / manufacturing standard 0.0500.9.0006
KM 500 R	0.002 mm	1 mm	0 – 100 / 0 – 100	40 mm	DIN EN ISO 463 / manufacturing standard 0.0500.9.0007
KM 1000 R	0.001 mm	1 mm	0 – 100 / 0 – 100	40 mm	DIN EN ISO 463 / manufacturing standard 0.0500.9.0007

Ideal for use in measuring fixtures

Dial Gauge M 2 R

with back plunger

Dial Gauge M 2/5 R

with back plunger

The models M 2 R and M 2/5 R differ only in their measuring ranges. Both Dial Gauges can be held either on the standard 8 mm h 6 stem or on the 28 mm diameter spigot.

Spindle and stem are made of resistant stainless steel. The spindle is lapped.

Dial Gauge M 2 R with back plunger	
Reading	0.01 mm
Range	3 mm
Range per revolution	1 mm
Bezel-Ø	58 mm
Stem-Ø	8 h 6
Dimensions and accuracy according to	DIN EN ISO 463 / manufacturing standard 0.0500.9.0006
Initial measuring force	1.5 N
Dimensioned drawing	page 46

Dial Gauge M 2/5 R with back plunger	
Reading	0.01 mm
Range	5 mm
Range per revolution	1 mm
Bezel-Ø	58 mm
Stem-Ø	8 h 6
Dimensions and accuracy according to	DIN EN ISO 463 / manufacturing standard 0.0500.9.0006
Initial measuring force	1.5 N
Dimensioned drawing	page 46



Model shown: M 2 R

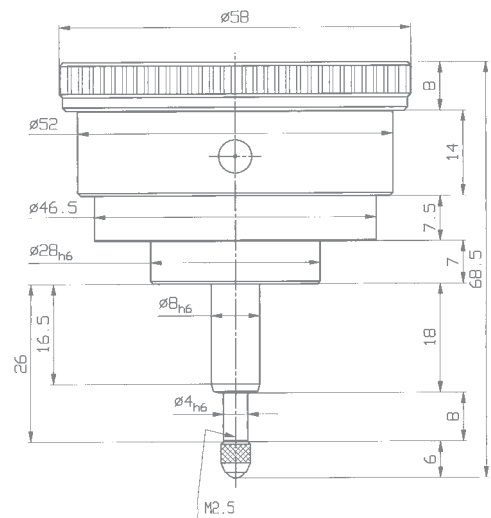

On the Dial Gauge M 2/5 R the dimension of 7.5 mm at $\varnothing 46.5$ mm in the above dimensioned drawing has been increased to 9.5 mm and the overall length from 68.5 mm to 70.5 mm.

Technical data for other Dial Gauges with back plunger					
Model	Reading	Range	Dial Numbering	Bezel Ø	Dimensions and accuracy according to
M 10/5 R	0.1 mm	5 mm	0 – 5	58 mm	DIN EN ISO 463 / manufacturing standard 0.0100.9.0004
SI-90 R	0.01 mm	0.8 mm	40 – 0 – 40	58 mm	DIN EN ISO 463 / manufacturing standard 0.0500.9.0006
SI-18 R	0.01 mm	1.6 mm	80 – 0 – 80	58 mm	DIN EN ISO 463 / manufacturing standard 0.0500.9.0006
FM 500 R	0.002 mm	1 mm	0 – 100 / 0 – 100	58 mm	DIN EN ISO 463 / manufacturing standard 0.0500.9.0007
FM 1000 R	0.001 mm	1 mm	0 – 100 / 0 – 100	58 mm	DIN EN ISO 463 / manufacturing standard 0.0500.9.0007